



Postbus 718, 6800 AS Arnhem, Nederland
 Autoriteit Consument en Markt
 T.a.v. de heer dr. F.J.H. Don
 Postbus 16326
 2500 BH DEN HAAG

DATUM 20 december 2019
 UW REFERENTIE
 ONZE REFERENTIE REC-N 19-079
 BEHANDELD DOOR [REDACTED]
 TELEFOON DIRECT [REDACTED]
 E-MAIL [REDACTED]@tennet.eu

VERZONDEN 20 DEC 2019

BETREFT Voorstel Channel TSO's voor gemeenschappelijke bepalingen ten aanzien van regionale coördinatie van operationele veiligheid op basis van artikel 76 van Verordening (EU) 2017/1485 (GL SO)

Geachte heer Don,

Hierbij ontvangt u een voorstel van de gezamenlijke TSO's van de Channel-regio voor gemeenschappelijke bepalingen ten aanzien van regionale coördinatie van operationele veiligheid. Het voorstel is gebaseerd op artikel 76 van de Verordening (EU) 2017/1485 van 2 augustus 2017 tot vaststelling van richtsnoeren betreffende het beheer van elektriciteitstransmissiesystemen (op basis van de Engelse titel afgekort als: GL SO). Het betreft:

"Channel TSOs common methodology for Regional Operational Security Coordination in accordance with article 76 of Commission Regulation (EU) 2017/1485 of 2 August 2017" d.d. 21 december 2019.

Bij dit voorstel is ter toelichting een *explanatory document* gevoegd.

Het voorstel bevat geen vertrouwelijke gegevens en kan integraal door u gepubliceerd worden.

U wordt verzocht het bijgevoegde voorstel goed te keuren krachtens artikel 6, eerste lid, van de GL SO.

Hoogachtend,
 TenneT TSO B.V.

[REDACTED]
 Senior Manager Regulation NL

Channel TSOs common methodology for
Regional Operational Security Coordination
in accordance with article 76 of Commission
Regulation (EU) 2017/1485 of 2 August 2017

'Channel ROSC Methodology'

21 December 2019

TABLE OF CONTENTS

| | |
|--|----|
| Whereas | 4 |
| Title 1 General Provisions | 5 |
| Article 1 Subject matter and scope | 5 |
| Article 2 Definitions and interpretation | 6 |
| Title 2 Regional Operational Security Coordination | 7 |
| Article 3 General provisions for ROSC..... | 7 |
| Article 4 Intraday regional security analysis | 8 |
| Title 3 Definition and determination of Channel XNEs, XRAs, constraints and contingencies | 8 |
| Article 5 Secured elements..... | 8 |
| Article 6 Scanned elements..... | 9 |
| Article 7 The list of secured elements and the list of scanned elements..... | 9 |
| Article 8 Cross-border relevant network elements | 9 |
| Article 9 Classification of remedial actions..... | 10 |
| Article 10 Cross-border relevance of remedial actions..... | 10 |
| Article 11 Qualitative assessment of XRAs..... | 11 |
| Article 12 Quantitative assessment of XRAs..... | 11 |
| Article 13 Contingency list | 12 |
| Title 4 Coordinated regional operational security analysis process..... | 12 |
| Chapter 1 Preparation..... | 12 |
| Article 14 Provision of the regional operational security inputs | 12 |
| Article 15 Preparation and updates of IGMs by Channel onshore TSOs..... | 12 |
| Article 16 Preparation and update of remedial actions by Channel onshore TSOs | 13 |
| Article 17 System constraints | 14 |
| Article 18 Preparation of secured and scanned elements and contingencies..... | 14 |
| Article 19 List of Agreed RAs..... | 14 |
| Article 20 Consistency and quality check of the input data..... | 14 |
| Chapter 2 Coordination..... | 15 |
| Article 21 General provisions of coordination process | 15 |
| Article 22 Power flow and security analysis | 15 |
| Article 23 Optimisation of remedial actions | 15 |
| Article 24 Time coupled optimisation | 16 |
| Article 25 Relieving operational security limit violations | 16 |
| Article 26 Avoid additional violations of operational security limits on secured and scanned elements..... | 17 |
| Article 27 Minimise incurred costs | 17 |
| Article 28 Balance of RAs..... | 17 |

| | |
|--|----|
| Article 29 RA effectivity..... | 17 |
| Article 30 Robustness..... | 17 |
| Article 31 Coordination of RAs..... | 18 |
| Article 32 Inter-CCR coordination | 18 |
| Chapter 3 Validation | 19 |
| Article 33 Validation session..... | 19 |
| Article 34 Outcome of validation | 19 |
| Chapter 4 Implementation of remedial actions | 19 |
| Article 35 Activation of remedial actions | 19 |
| Article 36 Consideration of remedial actions in next IGM..... | 20 |
| Article 37 Fast activation process | 20 |
| Title 5 Sharing of costs of remedial actions | 21 |
| Article 38 General provisions for cost sharing of remedial actions | 21 |
| Title 6 Monitoring and implementation..... | 21 |
| Article 39 Reporting | 21 |
| Article 40 Implementation | 21 |
| Title 7 Allocation of tasks by Channel RSCs | 23 |
| Article 41 Appointment of RSCs and delegation of tasks to Channel RSCs..... | 23 |
| Article 42 Allocation of tasks between Channel RSCs | 23 |
| Article 43 Efficiency and effectiveness of the allocation of tasks between Channel RSCs..... | 24 |
| Article 44 Coordination and decision-making process..... | 24 |
| Article 45 Rules concerning governance and operation of Channel RSCs..... | 24 |
| Title 8 Final provisions | 25 |
| Article 46 Publication of this Proposal..... | 25 |
| Article 47 Language..... | 25 |

WHEREAS

1. Commission Regulation (EU) 2017/1485 establishes a guideline on electricity transmission system operation (hereafter referred to as 'SO Regulation'), which entered into force on 2 August 2017.
2. This document is the common methodology of all Transmission System Operators (hereafter referred to as 'Channel TSOs') of the Channel Capacity Calculation Region (hereafter referred to as 'Channel CCR'), and defines the methodology for Regional Operational Security Coordination within the Channel CCR (hereafter referred to as 'Channel ROSC Methodology') in accordance with articles 76 and 77 of SO Regulation.
3. The Channel ROSC Methodology takes into account the general principles and goals set in the SO Regulation as well as Commission Regulation (EC) 2015/1222 establishing a guideline on Capacity Allocation and Congestion Management (hereafter referred to as 'CACM Regulation').
4. The Channel ROSC Methodology takes into account the possible dependencies with Commission Regulation (EU) 2017/2195 establishing a guideline on Electricity Balancing.
5. Article 76 of SO Regulation constitutes the legal basis for the Channel ROSC Methodology. Article 76 of SO Regulation defines that the Channel ROSC Methodology should address at least the following requirements:
 - (a) conditions and frequency of intraday coordination of operational security analysis and updates to the CGM by the RSC;
 - (b) the methodology for the preparation of remedial actions (hereafter referred to as "RAs") managed in a coordinated way, considering their cross-border relevance as determined in accordance with article 35 of CACM Regulation, taking into account the requirements in articles 20 to 23 of SO Regulation and determining at least: (i) the procedure for exchanging information about available RAs between relevant TSOs and the RSC; (ii) the classification of constraints and RAs in accordance with article 22 of SO Regulation; (iii) the identification of the most effective and economically efficient RAs in case of operational security limit violations referred to in article 22 of SO Regulation; (iv) the preparation and activation of RAs in accordance with article 23 (2) of SO Regulation; (v) the sharing of the costs of RAs referred to in article 22 of SO Regulation, complementing, where necessary, the common methodology developed in accordance with article 74 of CACM Regulation.
6. The Channel ROSC Methodology contributes to the objectives of article 76 of SO Regulation introducing a process which consists of a preparation phase as described in Chapter 1, a coordination phase as described in Chapter 2, a validation phase as described in Chapter 3 and an implementation phase as described in Chapter 4.
7. To identify the most effective and economically efficient RAs the Channel ROSC Methodology introduces an optimisation of RAs following the principles described in Article 23. The aim of the optimisation is to minimise the incurred cost in accordance with Article 27 on the one hand side and to ensure the RA effectivity in accordance with Article 29 on the other side.
8. For the exchange of relevant information and preparation of RAs the Channel ROSC Methodology describes all relevant input data relevant for executing the process in accordance with Article 14.
9. The Channel ROSC Methodology defines how the ROSC shall be applied in a coordinated manner in day-ahead and intraday within Channel CCR.

10. The Channel ROSC Methodology considers and, where necessary, complements the methodology for coordinating operational security analysis in accordance with article 75 of SO Regulation (hereafter referred to as 'CSAM').
11. The Channel ROSC Methodology considers and, where necessary, complements the Channel Capacity Calculation Region TSOs' proposal for the methodology for coordinated Redispatching and Countertrading (hereafter referred to as 'Channel RD and CT Methodology') in accordance with article 35 of CACM Regulation.
12. The Channel ROSC Methodology considers and, where necessary, complements the Channel Capacity Calculation Region TSOs' proposal for Redispatching and Countertrading Cost Sharing (hereafter referred to as 'Channel Cost Sharing Methodology') in accordance with article 74 of CACM Regulation.
13. In accordance with article 6(6) of SO Regulation, the Channel ROSC Methodology includes a timescale for its implementation.
14. The Channel ROSC Methodology contributes to the objectives of the SO Regulation concerning the maintaining of the operational security throughout the Union by specifying provisions for all TSOs and RSCs on the coordination of system operation and operational planning, transparency and reliability of information on transmission system operation, and the efficient operation of the electricity transmission system in the Union .
15. Furthermore, the Channel ROSC Methodology ensures application of the principles of proportionality and non-discrimination, transparency; optimisation between the highest overall efficiency and lowest total costs for all parties involved; and use of market-based mechanisms as far as possible, to ensure network security and stability.
16. In accordance with Recital (5) of the SO Regulation, synchronous areas do not stop at the European Union's (EU) borders and can include the territory of third countries. The TSOs should aim for secure system operation inside all synchronous areas stretching on the EU. They should support third countries in applying similar rules to those contained in this Regulation. ENTSO for Electricity should facilitate cooperation between EU TSOs and third country TSOs concerning secure system operation.
17. In conclusion, the Channel ROSC Methodology contributes to the general objectives of the SO Regulation to the benefit of all TSOs, the Agency, national regulatory authorities and market participants.

TITLE 1 GENERAL PROVISIONS

Article 1 Subject matter and scope

1. The Channel ROSC Methodology shall be considered as the methodology of Channel TSOs in accordance with article 76 of SO Regulation and for organisation for regional operational security coordination in accordance with article 77 of SO Regulation.
2. The Channel ROSC Methodology shall cover the day-ahead and intraday regional operational security coordination within Channel CCR. Channel ROSC Methodology shall apply to all Channel onshore TSOs and RSCs within the Channel CCR.
3. The Channel ROSC Methodology is subject to Channel NRA approval in accordance with article 6 (3)(b) of SO Regulation.

Article 2 Definitions and interpretation

1. In this Channel ROSC Methodology, the following acronyms are used:
 - a. 'ANORA' means 'Agreed but Not Ordered Remedial Action';
 - b. 'CGM' means the 'common grid model';
 - c. 'CGMM' means the methodology regarding articles 67 and 70 of SO Regulation;
 - d. 'CROSA' means 'Coordinated Regional Operational Security Assessment';
 - e. 'IGM' means the 'individual grid model';
 - f. 'RA' means 'remedial action';
 - g. 'RD and CT' means 'redispatching and countertrading';
 - h. 'ROSC' means 'Regional Operational Security Coordination'.

2. For the purposes of the Channel ROSC Methodology, the terms used shall have the meaning of the definitions included in article 3 of the SO Regulation, article 2 of CACM Regulation, article 2 of Commission Regulation (EU) No 543/2013 of 14 June 2013 on submission and publication of data in electricity markets and article 2 of CSAM. In addition, the following definitions shall apply:
 - a. 'Activated RA' means the ordered RA which has been agreed and implemented in the network by the TSO or by the resource provider;
 - b. 'Conditionally shared RA' means a shared RA whose applicability depends on conditions provided by the RA Connecting TSO;
 - c. 'CROSA Affected TSO' means a TSO which is affected by the full set of RAs resulting from CROSA with a remedial action influenced factor greater than the threshold defined in article 15 (5) of CSAM.
 - d. 'Non-Shared RA' means a RA used to relieve specific operational security limits violations and not available for the global optimisation;
 - e. 'Ordered RA' is the subset of the agreed remedial action that is bindingly ordered by the RA Requesting TSO and RA Connecting TSO;
 - f. 'RA Connecting TSO' means the TSO responsible for the control area where the RA is located or connected or activated;
 - g. 'RA Requesting TSO' means the TSO responsible for the operation of the control area where the violation of operational security limits is detected. In case of a violation of operational security limits on a cross-border transmission line, both TSOs responsible for the operation of that line are considered to be RA Requesting TSOs;
 - h. 'Secured Element' means an assessed element on which, when violations of an operational security limit are identified during the regional or cross-regional security analysis, remedial actions are needed in order to relieve these violations.
 - i. 'Scanned Element' means an assessed element on which the electrical state (at least flows) may be computed and may be subject to an observation rule during the regional security analysis process. Such an observation rule can be for example to avoid increasing a constraint or to avoid creating a constraint on this element, as a result of the design of remedial actions needed to relieve violations on the secured elements.
 - j. 'Shared RA' means a RA available for the global optimisation to relieve operational security limit violations;
 - k. Channel onshore TSOs – means TSOs in charge of load-frequency control area within Channel CCR.

3. The following types of constraints are considered in this methodology:

- a. Operational security constraints: constraints in line with SO Regulation mean a situation in which there is a need to prepare and activate a RA in order to respect operational security limits. The consideration of these constraints within Channel ROSC Methodology is further defined in Article 25. The constraints consist of the following:
 - i. Currents and voltages exceeding operational security limits;
 - ii. Violations of stability limits of the transmission system identified in accordance with article 38 (2) and article 38 (6) of SO Regulation;
 - iii. Violations of short-circuit current limits of the transmission system.
 - b. Constraints on remedial actions: constraints related to all aspects required to be taken into account when using RAs and classified as following:
 - i. Technical constraints are all the rules related to the technical limitations for resources for redispatching and countertrading in accordance with Channel RD and CT Methodology or network elements;
 - ii. Operational constraints are all the operational conditions and usage rules taking into account the timings to operate the network and avoid a premature ageing of the network elements;
 - iii. Procedural constraints are all the timing constraints due to local or regional processes;
 - iv. Legal constraints are the legal requirements stated in national laws regarding the priority of activation of RAs.
 - c. Additional optimisation constraints called system constraints are all the optimisation constraints added by Channel onshore TSOs, expressed as flow limitation on a single or a set of Secured and Scanned Elements and necessary to respect stability limits or operational security limits other than current limits. These are further detailed in Article 17.
4. In this Channel ROSC Methodology, unless the context requires otherwise:
- a. The singular indicates the plural and vice versa;
 - b. Headings are inserted for convenience only and do not affect the interpretation of this Channel ROSC Methodology;
 - c. Any reference to legislation, regulations, directives, orders, instruments, codes or any other enactment shall include any modification, extension or re-enactment of it when in force.

TITLE 2 REGIONAL OPERATIONAL SECURITY COORDINATION

Article 3 General provisions for ROSC

1. Channel onshore TSOs in coordination with Channel RSCs shall execute the ROSC for each hour of the target day. The ROSC is composed of the following activities:
 - a. Channel onshore TSOs and Channel RSCs shall perform day-ahead and intraday CROSA. Day-ahead CROSA shall be performed in accordance with the timings of article 45 of CSAM. Intraday CROSA shall be performed at least three times in intraday timeframe in accordance with article 24 of CSAM. Each CROSA shall consist of:
 - i. Preparation as described in Chapter 1 of Title 4;
 - ii. Coordination as described in Chapter 2 of Title 4;
 - iii. Validation as described in Chapter 3 of Title 4.

- b. Channel onshore TSOs shall implement the Agreed RAs in the subsequent IGMs and Channel onshore TSOs shall activate the Ordered RAs following the provisions in accordance with Articles 35 and 36.
- c. Channel onshore TSOs shall have the right to modify an Ordered RA or may activate a new RA following the fast activation process in accordance with Article 37.

Article 4 Intraday regional security analysis

1. In addition to ID CROSA, Channel onshore TSOs with Channel RSCs shall perform intraday regional security analysis ('ID RSA').
2. The goal of the ID RSA is to provide Channel onshore TSOs each hour of the day with the latest information about the loading of the transmission system and previously undetected violations of operational security limits, which may serve as a trigger for a fast activation process.
3. This ID RSA shall be performed at each hour of the day for each timestamp until the end of the day.
4. ID RSA shall be performed on the updated IGMs containing the latest available forecast of generation and load, planned and forced outages, Agreed RAs and Ordered RAs.
5. For the purpose of ID RSA, each Channel onshore TSOs shall provide every hour IGMs for all remaining hours of the day, respecting CGMM provisions for their content and including all Agreed RAs resulting from latest CROSA or fast activation process.
6. RSCs shall merge updated IGMs into an updated CGM, perform a load flow and contingency analysis calculation and deliver the results to all Channel onshore TSOs.

TITLE 3 DEFINITION AND DETERMINATION OF CHANNEL XNES, XRAS, CONSTRAINTS AND CONTINGENCIES

Article 5 Secured elements

1. Secured elements shall represent a set of network elements in the Channel CCR with a voltage level higher than or equal to 220 kV subject to the CROSA, on which operational security limits violations need to be managed in a coordinated way.
2. The secured elements shall be identified as cross-border relevant network elements (XNEs) in accordance with CSAM within the Channel CCR.
3. Channel onshore TSOs shall have a right to exclude any element from the secured elements set that fulfils one of the following criteria:
 - a. Element is a power plant line;
 - b. Element is a radial line;
 - c. Element is connected to a DSO;
 - d. Element is a transformer with the secondary voltage side lower than 220 kV.
4. Channel onshore TSOs shall have the right at any time to exclude any element from the secured elements set, except mandatory elements defined in paragraph 3, if there is a common agreement between Channel onshore TSOs that such element may be excluded.
5. Channel onshore TSOs, which are part of more than one CCR, shall have the right to exclude any element from the secured elements set which is subject to CROSA within other CCRs.

6. The list of excluded elements from the secured elements set shall be shared with the respective Channel RSCs and among Channel onshore TSOs.
7. Each Channel onshore TSO shall have the right at any time to include any element with a voltage level higher than or equal to 220 kV in the secured elements set.

Article 6 Scanned elements

1. Scanned elements shall represent a set of elements on which CROSA shall not create new operational security limits violations or worsen any existing violation. Each Channel onshore TSO may, for CROSA purposes only, deviate from this by setting individual thresholds for the scanned elements of its IGM.
2. Channel onshore TSOs shall have the right at any time to include any element excluded from the secured elements set in the scanned elements set.
3. Channel onshore TSOs shall have the right at any time to include any element with a voltage level lower than 220 kV in the scanned elements set, which is modelled in its IGM, providing justification for its inclusion.
4. Channel onshore TSOs shall have the right at any time to exclude any element from the scanned elements set.

Article 7 The list of secured elements and the list of scanned elements

1. By three months after the approval of this methodology, Channel onshore TSOs with the support of the respective Channel RSCs shall define the list of secured elements and the list of scanned elements in accordance with Article 5 and Article 6.
2. If a new element with a voltage level higher than or equal to 220 kV is commissioned, it shall be included in the secured elements list, unless the Channel onshore TSO operating this element decides not to include it in the secured elements list in accordance with Article 5.
3. If a new element with a voltage level lower than 220 kV is commissioned, the Channel onshore TSO operating this element may decide to include it in the scanned elements list in accordance with Article 6.
4. Each Channel onshore TSO shall have the right at any time to move any element it operates with a voltage level higher than or equal to 220 kV from the scanned elements list to the secured elements list.
5. Channel onshore TSOs shall update the secured elements list and scanned elements list when necessary and inform the Channel RSCs about the change. The lists of secured elements and the list of scanned elements shall be reassessed by Channel onshore TSOs at least once a year.
6. Channel RSCs shall use the latest lists of secured elements and scanned elements shared by the Channel onshore TSOs.

Article 8 Cross-border relevant network elements

1. The list of secured elements defined in accordance with Article 7, represents the list of cross-border relevant network elements of Channel CCR, hereafter 'Channel XNEs'.
2. Costs incurred for solving violations on Channel XNEs shall be shared in accordance with the rules and criteria described in Channel Cost Sharing Methodology.

Article 9 Classification of remedial actions

1. Each Channel onshore TSO shall classify the RAs in accordance with article 22 of SO Regulation.

Article 10 Cross-border relevance of remedial actions

1. Within one month after the list of secured elements set has been defined in accordance with Article 7, Channel onshore TSOs shall share with the Channel RSCs all potential RAs, designed in accordance with article 14 of CSAM, which are at least generally able to address violations of current limits.
2. Channel onshore TSOs, in coordination with Channel RSCs, shall jointly assess the cross-border relevance of potential RAs shared by Channel onshore TSOs in accordance to paragraph 1.
3. Channel onshore TSOs shall aim at agreeing on a qualitative approach in accordance with Article 11 to determine RAs that are deemed cross-border relevant and to determine the corresponding TSOs affected by those RAs.
4. If Channel onshore TSOs cannot agree on a qualitative approach, in accordance with Article 11, for a certain RA a quantitative approach in accordance with Article 12 shall be used for this RA.
5. Channel onshore TSOs shall jointly define and share with the Channel RSCs the list of RAs that are deemed cross-border relevant.
6. Reassessment of the list of cross-border relevant RAs shall be done on a yearly basis by Channel onshore TSOs with the support of Channel RSCs.
7. If a new RA is designed in day-ahead or intraday operational planning, each Channel onshore TSO shall assess its cross-border relevance using a quantitative approach in accordance with article 15 (5) of CSAM.
8. The RA influence factor computation for RAs described in paragraph 7 shall be performed on the latest available CGM.
9. If a new RA is designed between two mandatory assessments in accordance with paragraph 6 and prior to day-ahead operational planning, each Channel onshore TSO shall assess its cross-border relevance in accordance with Article 11. In case Channel onshore TSOs cannot agree on the result of the qualitative approach, a quantitative approach in accordance with Article 12 shall be assessed.
10. Channel onshore TSOs shall delegate the task described in paragraph 7 to Channel RSCs.
11. If a new RA is designed by a Channel onshore TSO during real time operation and if the system is in alert state in accordance with SO Regulation, the RA Connecting TSOs shall use quantitative assessment in order to identify if this RA is cross-border relevant. When doing this, the RA Connecting TSOs shall check that the activation of such RA does not lead to violations of operational security limits on elements of its observability area using either the latest available common grid model or its model from the state estimator. If such analysis shows that activation of RAs may cause violations on elements of its observability area, its activation has to be coordinated with the TSOs where the violation occurs.
12. In an emergency state, Channel onshore TSOs shall apply the provision of article 16 (4) of CSAM.
13. Between two mandatory assessments of RAs in accordance with paragraph 6, each Channel onshore TSO shall have the right to request an additional assessment of a RA providing justification for such a request to the RA Connecting TSO and respective Channel RSCs.

14. During fast activation process, when a Channel onshore TSO proposes an XRA in accordance with paragraphs 3 and 4 of article 17 of the CSAM and when this TSO is the RA Connecting TSO as well as the only XRA affected TSO, the activation of this XRA shall not be subject to further coordination.
15. If a RA is not identified as cross-border relevant in accordance with Article 11 and Article 12, it shall be considered as non-cross-border relevant.

Article 11 Qualitative assessment of XRAs

1. Channel onshore TSOs, with the support of Channel RSCs, shall jointly establish a list of potential RAs provided by Channel onshore TSOs to Channel RSCs in accordance with Article 10 (1).
2. For each RA included in the list defined in paragraph 1:
 - a. Each Channel onshore TSO shall individually assess the cross-border relevance of the RA on its control area;
 - b. Each RA Connecting TSO shall assess the cross-border relevance of the RA on control areas of other Channel onshore TSOs and also on its control area;
 - c. If the RA is quantifiable such as redispatching, countertrading, change of set point on HVDC systems or change of taps on phase-shifting transformers, the quantity above which this RA is deemed cross-border relevant on the control areas of other TSOs and its control area has to be specified in accordance with article 15 (7) of CSAM;
3. Channel onshore TSOs may delegate the tasks described in paragraph 2 to their respective Channel RSC.
4. Each Channel onshore TSO shall propose RAs, considered by that Channel onshore TSO as being cross-border relevant providing justification for their selection to RA Connecting TSOs.
5. If a common agreement among Channel onshore TSOs is reached, then the RA is defined as cross-border relevant and all XRA affected TSOs are identified.
6. If a RA is not proposed as cross-border relevant by any Channel onshore TSO, it is considered as non-cross-border relevant.
7. If a RA is identified as cross-border relevant only by the RA Connecting TSO, this TSO shall be considered as the only XRA affected TSO.

Article 12 Quantitative assessment of XRAs

1. Channel onshore TSOs shall use the CGMs established in accordance with article 67 of the SO Regulation when computing remedial action influence factor in accordance with article 15 of CSAM.
2. Each Channel onshore TSO shall provide a list of elements on which the influence of a RA shall be assessed. The assessment shall be done at least on the XNEC elements in accordance with article 15 (4) of CSAM.
3. The remedial action influence factor shall be calculated in accordance with article 15 (4) and article 15 (5) of CSAM for RAs for which an agreement on using a qualitative approach in accordance with Article 11 could not be reached.
4. If a RA consists of a combination of actions, its cross-border relevance shall be assessed for the effect of the combination.
5. Channel onshore TSOs shall delegate the task of performing calculations of remedial action influence factors to the Channel RSCs.

6. All RAs for which an influence factor for at least one XNEC is greater than the threshold defined in article 15 (5) of CSAM shall be considered as cross-border relevant, otherwise the RAs shall be considered as non-cross-border relevant.
7. All Channel onshore TSOs that have at least one affected XNEC for which the remedial action influence factor is greater than the threshold shall be considered as XRA affected TSOs, in accordance with article 15 (8) of CSAM.

Article 13 Contingency list

1. Each Channel onshore TSO shall establish the list of contingencies to be simulated in operational security analysis in accordance with article 10 of the CSAM, hereafter referred to as "Contingency List".
2. Each Channel onshore TSO shall provide the respective Channel RSCs and Channel onshore TSOs with the Contingency List to be used in CROSA and shall inform the Channel RSCs about any update of this list in accordance with article 11 of CSAM.
3. Channel RSCs shall use the latest Contingency Lists shared by the Channel onshore TSOs.

TITLE 4 COORDINATED REGIONAL OPERATIONAL SECURITY ANALYSIS PROCESS

CHAPTER 1 PREPARATION

Article 14 Provision of the regional operational security inputs

1. Each Channel onshore TSO shall provide the following input data to Channel RSCs:
 - a. IGM according to Article 15, including the operational security limits for each secured or scanned element according to Articles 5 and 6;
 - b. Available remedial actions within its control area according to Article 16;
 - c. When relevant, System Constraints according to Article 17;
 - d. Secured and scanned elements according to Articles 5 and 6;
 - e. Contingency List according to Article 13.
2. The input data shall cover all hours for a business day related to intraday and day-ahead CROSA.
3. Channel onshore TSOs shall deliver or update when required the input data before the commonly agreed process deadlines.

Article 15 Preparation and updates of IGMs by Channel onshore TSOs

1. Each Channel onshore TSO shall prepare and deliver day-ahead and intraday IGMs for day-ahead and intraday coordinated regional operational security assessments as defined in CSAM and the methodology in accordance with article 70 (1) of SO Regulation.
2. Channel onshore TSOs shall have the right to perform local preliminary assessments. When preparing IGMs, each Channel onshore TSO shall have the right to include RAs resulting from these local preliminary assessments in accordance with article 21 (3) of CSAM which were performed by Channel onshore TSOs before the first day-ahead CROSA.

3. When preparing IGMs, Channel onshore TSOs shall have the right to include non-cross-border relevant remedial actions in accordance with article 21 (4) of CSAM resulting from local preliminary assessments performed by Channel onshore TSOs at any time.
4. If Channel onshore TSOs include Redispatching and Countertrading in their IGMs resulting from preliminary assessments in accordance with paragraph 2 and 3 of Article 15, the information on ordered Redispatching and Countertrading shall be shared among Channel onshore TSOs in order to be clearly distinguishable from the network topology without RAs applied in accordance with article 70 (4) of SO Regulation.
5. In case the methodology in accordance with article 21 of CSAM is amended as requested by article 21 (6) of CSAM, the provisions of the amended article 21 of CSAM shall suspend paragraph 2 and 3 of Article 15 if the amendment is related to these paragraphs.
6. If the result of the optimisation contains agreed remedial actions for the respective control area, each Channel onshore TSO shall provide to Channel RSCs an updated IGM between two coordination runs in accordance with article 33 (1)(c) of CSAM and articles 3 and 4 of CGMM. The RAs resulting from the first coordination run are not binding and shall be possible to be changed by the optimisation function during the second coordination run if deemed unnecessary.

Article 16 Preparation and update of remedial actions by Channel onshore TSOs

1. Each Channel onshore TSO shall make available all potential RAs to the Channel RCSs for day-ahead and intraday coordinated regional operational security assessments as defined in CSAM.
2. When identifying the RAs that shall be made available, each Channel onshore TSO shall take in consideration the following principles:
 - a. Define the RAs in line with the categories of article 22 of SO Regulation considering the provisions stated in articles 10 and 11 of the Channel RD and CT Methodology;
 - b. Assess the availability of the XRAs defined according to Article 10;
 - c. Consider non-XRAs, as defined according to Article 10, which could have an impact on any of the secured or scanned element of his control area;
 - d. Assess the availability of the RAs which were available for the previously performed CROSAs or capacity calculation of the same hour and the previously ANORAs;
 - e. Consider the RAs as not available only under the following conditions:
 - i. an unforeseen event, or
 - ii. an unplanned outage, or
 - iii. a declaration of unavailability status done by a third party owning the assets providing the remedial action, or
 - iv. any other cause outside of the responsibility of the Channel TSO;
 - f. Identify whether a RA provided to Channel CCR is an overlapping XRA according to article 27(3) of CSAM;
 - g. Identify whether a RA is shared, non-shared or conditionally shared and additionally provide a justification to Channel RSCs and Channel onshore TSOs why a RA is non-shared or conditionally shared;
 - h. Identify to which CCR a RA is also made available.
3. Channel onshore TSOs shall provide any relevant information for each RA for the purpose of day-ahead and intraday regional operational security coordination process that will reflect the technical, operational or procedural constraints of the RA as defined in accordance with Article 2.

4. In case of a second coordination run of the coordination stage of DA or ID CROSA, each Channel onshore TSO shall provide to the Channel RSCs an updated list of RAs, considering:
 - a. The agreed outcome of the latest coordination run for the RAs in accordance with Article 31 and 32;
 - b. Any unplanned or forced outages or changes of outage schedules of relevant assets;
 - c. If relevant the latest schedules of load and generation.

Article 17 System constraints

1. Each Channel onshore TSO shall have the right to make available to Channel RSCs System constraints in accordance with Article 2 for the purpose of dynamic stability, voltages exceeding operational security limits in the N-situation and after occurrence of a contingency from the Contingency List described in Article 13.
2. The System constraints, for the purpose of dynamic stability, shall be defined based on the criteria on dynamic system stability in accordance with articles 38 and 39 of SO Regulation.
3. When applying such System constraints, the concerned Channel onshore TSO shall provide to other Channel onshore TSOs and Channel RSCs the reasoning of these System constraints in a transparent manner.
4. If relevant, each Channel onshore TSO shall provide to the Channel RSCs updated System constraints, at the end of any coordination run of the coordination stage of day-ahead or intraday CROSA.

Article 18 Preparation of secured and scanned elements and contingencies

1. Each Channel onshore TSO shall make available the list of Secured and Scanned Elements for its control area to the Channel RSCs for day-ahead and intraday CROSA in accordance with the principles defined in Article 7.
2. Each Channel onshore TSO shall make available the Contingency List for its control area to the Channel RSCs for day-ahead and intraday CROSA pursuant to the principles defined in Article 13 developed in line with CSAM.

Article 19 List of Agreed RAs

1. The Channel RSCs shall make available for intraday CROSA the list of Agreed RAs logged by Channel RSCs in accordance with Article 36.

Article 20 Consistency and quality check of the input data

1. The Channel RSCs shall assess the consistency and quality of each input data file provided by each Channel onshore TSO in accordance with CGMM and CSAM.
2. Channel RSCs shall monitor if the Agreed RAs are included in the IGMs provided by each Channel onshore TSO.
3. The Channel RSCs and Channel onshore TSOs shall inform the concerned Channel onshore TSOs on the identified issues in accordance with paragraphs 1 and 2 in an appropriate timeframe before starting the remedial action optimisation to give Channel onshore TSOs the opportunity to correct these errors or inconsistencies and provide updated input files.

CHAPTER 2 COORDINATION

Article 21 General provisions of coordination process

1. Channel RSCs in coordination with Channel onshore TSOs shall perform the day-ahead and intraday CROSA in accordance with articles 23 and 24 of CSAM.
2. At day-ahead stage, CROSA will include two coordination runs and at the intraday stage CROSA will include at least one coordination run. Each coordination run will consist of the following steps:
 - a. Building of the CGMs by the Channel RSCs in accordance with CGMM;
 - b. Running power flow and security analysis in accordance with Article 22;
 - c. Remedial actions optimization in accordance with Articles 23 to 30;
 - d. Remedial actions coordination in accordance with Article 31;
 - e. Inter-CCR coordination in accordance with Article 32.
3. Within ENTSO-E, TSOs will set-up a consistent and harmonised approach at pan-European level to ensure that the solutions implemented to build CGMs and operated by RSCs will be compliant with the respective requirements set up in the relevant legislation in force, including SO Regulation (notably article 79 (5) of SO Regulation), the CGMM and the CSAM, while ensuring reliability of the CGM delivery process and the aligned use of the resulting unique CGM.
4. Each Channel onshore TSO shall update the input data for the second coordination run in the day-ahead stage in accordance with the provisions defined in the Articles 14 – 20.
5. In the intraday CROSA, Channel onshore TSOs and Channel RSCs shall reassess the ANORAs in accordance with Article 36 and that were agreed in the day-ahead CROSA or previous Intraday CROSA for the period until the results of the following Intraday CROSA are available.
6. Information about Ordered RAs and ANORAs during day-ahead and Intraday CROSA shall be logged by Channel RSCs.

Article 22 Power flow and security analysis

1. Channel RSCs shall perform the power flow and security analysis by using the CGM built in accordance with CGMM. The security analysis will be performed considering the latest Contingency List as well as the latest list of secured and scanned elements provided by the Channel onshore TSOs.
2. Channel RSCs shall provide to all Channel onshore TSOs the power flow and operational security analysis results.
3. Channel onshore TSOs shall have the opportunity to validate the power flow and operational security analysis results. This validation aims at identifying input mistakes which would make the outcomes of the operational security analysis non-realistic and to give Channel onshore TSOs the opportunity to correct these errors.
4. In case of the detection of input mistakes, Channel onshore TSOs shall update their input files in accordance with Article 20 (3).

Article 23 Optimisation of remedial actions

1. Channel onshore TSOs and Channel RSCs shall optimise RAs in order to identify in a coordinated way the most effective and economically efficient RAs, based on following principles:
 - a. The optimisation of RAs shall be performed with consideration of all available RAs;

- b. The optimisation is time-coupled in accordance with Article 24;
- c. The optimisation of RAs shall aim at relieving operational security limit violations on secured elements in accordance with Article 25;
- d. The optimisation shall not create additional operational security limit violations on secured and scanned elements in accordance with Article 26;
- e. The optimisation shall aim at minimising incurred costs in accordance with Article 27;
- f. The optimisation shall consider constraints of the RAs in accordance with Article 2 (3);
- g. The optimisation shall propose balanced RAs in accordance with Article 28;
- h. The optimisation shall ensure the RA effectivity in accordance with Article 29;
- i. The optimisation shall take into account the impact of variations in forecasts and market activities in accordance with Article 30.

Article 24 Time coupled optimisation

1. The optimisation of RAs shall be time-coupled in the identification of the most effective and economically efficient RAs.
2. In the optimisation for day-ahead all hours of the day shall be optimised.
3. For intraday all remaining hours until the end of the day shall be optimised.
4. In the optimisation for both day-ahead and intraday, any constraints in accordance with Article 2 on Agreed RAs from previous hours shall be taken into account.

Article 25 Relieving operational security limit violations

1. When performing day-ahead and intraday CROSA, Channel onshore TSOs and Channel RSCs shall detect if currents violate operational security limits in N-situation or after occurrence of a contingency.
2. In intraday CROSA the detection of current limits violations in accordance with paragraph 1 shall be performed on CGMs after removal of ANORAs.
3. For the detection of other constraints, such as voltage violations, violations of short-circuit current limits or violations of stability limits, each Channel onshore TSO should perform local assessment and long-term operational security analysis in accordance with articles 31, 38 and 73 of SO Regulation. When applying such constraints, the concerned Channel onshore TSO shall provide to other Channel onshore TSOs and Channel RSCs the reasoning of these constraints in a transparent manner.
4. Other constraints than current limits may be reflected into system constraints in accordance with Article 17.
5. The optimisation process shall aim at identifying RAs from a list of non-costly and costly RAs made available by Channel onshore TSOs in accordance with Article 16 to relieve operational security limit violations on secured elements, detected in accordance with paragraph 1. The list of available RAs shall include the ANORAs that have been removed in accordance with paragraph 2 unless ANORAs are no longer technically available.
6. Curative RAs shall be used for relieving operational security limit violations in contingency case on a secured element as long as the temporarily admissible thermal limit of the element is not exceeded. Under consideration of all recommended preventive and curative RAs, the permanent admissible thermal limit of the secured elements shall be respected.

Article 26 Avoid additional violations of operational security limits on secured and scanned elements

1. The activation of RAs identified for relieving operational security limit violations on secured elements:
 - a. Shall not lead to additional violations of operational security limits on secured and scanned elements;
 - b. Shall not worsen existing operational security limits violations on scanned elements in accordance with Article 6.
2. On request of Channel onshore TSOs and in case a scanned element constrains the optimisation in a significant frequency, the Channel onshore TSO who has defined this scanned element shall assess possibilities to reduce its constraining character.

Article 27 Minimise incurred costs

1. The optimisation shall aim at minimising the incurred costs which are defined by the Channel RD and CT Methodology, resulting from the indicative price or costs information of the costly RAs used to relieve operational security limit violations.
2. The minimisation of costs shall take into account the effectivity of RAs in accordance with Article 29.

Article 28 Balance of RAs

1. In order to guarantee the balance of the system after activation of RAs, the optimisation shall ensure that the identified RAs are balanced and can be activated in a balanced way in each timeframe.

Article 29 RA effectivity

1. The optimisation shall include computation of the flow sensitivity of RAs.
2. The flow sensitivity of a RA reflects the variations of power flow or current on secured and scanned elements as a function of their nominal power flow or current.
3. The flow sensitivity of a RA shall be balanced with their direct costs in order to ensure the selection of the most economically efficient and technically effective RAs.
4. The optimisation shall localize any remaining operational security limits violations and flows.

Article 30 Robustness

1. Taking into account all the principles introduced in Articles 23 to 29, the optimisation shall ensure that the identified RAs for relieving operational security limit violations on the secured elements are robust to variations of forecasts in consumption, RES production, and market activities and allow Channel onshore TSOs to operate their control area without violation of operational security limits.

2. In case of exceptional situations, such as but not limited to unpredictable arrival of a wind front or snowfall on PV modules, where the accuracy of one or more of the forecasts variables included in the IGMs is insufficient to allow the correct identification of operational security limit violations, Channel onshore TSOs shall have right to change thermal limits of their XNEs in regional day-ahead or intraday processes in accordance with articles 23 (4) and 24 (4) of CSAM.
3. Concerned TSOs shall inform without undue delay Channel onshore TSOs and Channel RSCs in case of application of paragraph 2, providing at least following information:
 - a. Elements and timestamps which are affected by the application of the paragraph 2;
 - b. Estimate of the time for which application of paragraph 2 is needed.
4. In case of application of paragraph 2, the concerned Channel onshore TSOs shall provide ex-post on request its justification about its decision to other Channel onshore TSOs and Channel RSCs.

Article 31 Coordination of RAs

1. In day-Ahead and intraday CROSA, Channel onshore TSOs in coordination with Channel RSCs shall manage in a coordinated way, operational security violations on all secured elements considering all RAs in accordance with article 17 of CSAM. To this end, Channel RSCs shall make recommendations for the implementation of the most effective and economically efficient RAs to the concerned Channel onshore TSOs according to the result of the optimisation in accordance with Article 23.
2. During each CROSA, RA Connecting TSOs and CROSA affected TSOs shall decide whether to agree or reject proposed RAs in accordance with article 78 (4) of the SO Regulation and article 17 of CSAM.
3. In case all RA Connecting TSOs and CROSA affected TSOs agree on a proposed RA, this RA is deemed agreed by Channel onshore TSOs.
4. If a Channel onshore TSO rejects a RA proposed by Channel RSCs the reasons shall be justified, documented by the relevant Channel onshore TSO(s) and provided to Channel RSCs, in accordance with article 78 (4) of the SO Regulation.
5. If a Channel onshore TSO rejects a proposed RA, except in the case of an unavailability of the proposed RA, the respective Channel onshore TSO shall be able to perform an ex-post assessment to determine the additional costs and impact resulting from the rejected RA on the congestion. These costs and impact shall be compared with the costs and impact on congestion resulting from possible RAs not regarded in the CROSA and Fast Activation Process, which would lead to an acceptance of the rejected RA. If a proposed RA is rejected by a Channel onshore TSO due to a specific reason frequently, the rejecting Channel onshore TSO shall, at the request of the affected Channel onshore TSO, perform an ex-post assessment.
6. In case of rejection of a proposed RA, the concerned Channel onshore TSOs shall coordinate with Channel RSCs and other Channel onshore TSOs to identify and plan alternative RAs taking into account cost and efficiency to relieve the operational security limits violations in a coordinated way in accordance with Channel ROSC Methodology and article 17 (7) of CSAM.

Article 32 Inter-CCR coordination

1. Channel RSCs and relevant other RSCs in coordination with Channel onshore TSOs shall relieve operational security limits violations on overlapping XNEs and shall coordinate XRA impacting

- these overlapping XNEs in accordance with the proposal for amendment to be developed in accordance with article 27(3) of CSAM.
2. Channel RSCs shall perform the coordinated cross-regional operational security assessment with relevant other RSCs in accordance with article 30 of CSAM.
 3. Channel RSCs shall consider and coordinate with relevant other RSCs the use of RA potential of adjacent CCRs in accordance with the proposal for amendment to be developed in accordance with article 27(3) of CSAM.
 4. Until the amendment of article 27(3) CSAM is implemented, Channel onshore TSOs and RSCs shall continue applying the existing bilateral and/or multilateral operational agreements with TSOs and RSCs of other CCRs.

CHAPTER 3 VALIDATION

Article 33 Validation session

1. In the end of the day-ahead CROSA in accordance with article 33 (1)(f) of CSAM, a session shall be hosted by Channel RSCs in order to consolidate results of the day-ahead CROSA and for Channel onshore TSOs to reach a final agreement and acknowledge RA that have been agreed during the day-ahead CROSA.

Article 34 Outcome of validation

1. All Ordered RAs and ANORAs shall be logged after the validation session.
2. Remaining violations of operational security limits must be reported. The next steps shall be specified and may include but not limited to an intraday CROSA or fast activation process.
3. Channel RSCs shall ensure the availability of results and decisions to all Channel onshore TSOs.
4. Channel RSCs shall archive all necessary data for the yearly report in accordance with article 17 of SO Regulation.

CHAPTER 4 IMPLEMENTATION OF REMEDIAL ACTIONS

Article 35 Activation of remedial actions

1. Each RA Connecting TSO shall activate RAs at the latest time compatible with technical, operational and procedural constraints of the resources in accordance with article 19 of CSAM.
2. In case of activating Redispatching or Countertrading, the RA connecting TSO shall apply the provisions of article 14 of Channel RD and CT Methodology.
3. Each Channel onshore TSO shall have the right to request a reassessment of Ordered RAs or already activated RAs in case the RAs are not required anymore and considering technical, operational and procedural constraints. XRA affected Channel onshore TSO shall reassess the Ordered RAs via fast activation process in accordance with Article 37.
4. The Channel onshore TSOs shall update in a coordinated manner the available cross-zonal capacities within the intraday or balancing timeframe by taking account the activation of XRAs. The updated capacities shall not aggravate the operational security.

Article 36 Consideration of remedial actions in next IGM

1. All Agreed RAs shall be classified based on a possibility of their reassessment in later CROSA:
 - a. If activation time of an RA prevents waiting for next CROSA for possible reassessment, then the RA shall be classified as Ordered RAs. Only fast activation process can change the status of an Ordered RA;
 - b. If a reassessment of the RA in the next CROSA is a possibility, then the RA shall be classified as ANORA.
2. Each Channel onshore TSO shall include all RAs agreed during the latest CROSA in the intraday IGMs according to the provision of articles 20 and 21 of CSAM. Information about all RAs agreed during day-ahead and intraday CROSA shall be logged by Channel RSCs.
3. Channel RSCs shall monitor the inclusion of Agreed RAs into IGMs in accordance with article 28 of CSAM.

Article 37 Fast activation process

1. A Channel onshore TSO shall trigger the fast activation process to relieve operational security limit violation(s) in case the detection of the physical congestion occurs:
 - a. Between CROSA cycles and a fast activation of a XRAs is required because it cannot wait for the next CROSA;
 - b. After the latest CROSA.
2. The fast activation process shall also be considered as a fallback where coordination through the Channel RSCs is no longer possible due to insufficient time and the regular process described in Article 21 could not be properly applied.
3. A Channel onshore TSO shall trigger the fast activation process in the case that an Ordered RA is an XRA and is not available anymore.
4. During the fast activation process RA connecting TSOs and XRA affected TSOs shall coordinate among each other to identify, plan and activate alternative RAs to relieve the operational security limits violations in a coordinated way while respecting the relevant provisions of article 17 of CSAM.
5. In the fast activation process, the activation of preventive as well as curative XRAs may be applied.
6. In the fast activation process, each Channel onshore TSO may activate XRAs in direct coordination with XRA affected TSOs in accordance with the principles for coordination of XRAs described in CSAM.
7. The Channel onshore TSO activating XRAs through fast activation process shall provide the Channel RSCs the relevant information on which the decision was based.
8. The fast activation process ends once RAs to relieve the violation are identified, coordinated and agreed. These RAs will be considered as Agreed RAs.
9. Channel onshore TSOs will take into account the Activated RAs in the next relevant IGMs. New congestions as a result of those RAs should be avoided.

TITLE 5 SHARING OF COSTS OF REMEDIAL ACTIONS

Article 38 General provisions for cost sharing of remedial actions

1. Any Activated RAs, which are Agreed RAs resulting from CROSA and fast activation process in accordance with this Channel ROSC Methodology, are subject to the cost sharing principles in accordance with Channel Cost Sharing Methodology.
2. Each Channel onshore TSO and the Channel RSCs shall provide all needed information about these Activated RAs to ensure the application of the Channel Cost Sharing Methodology.

TITLE 6 MONITORING AND IMPLEMENTATION

Article 39 Reporting

1. RAs will be reported by Channel onshore TSOs as described in the article 13 (1) of Transparency Regulation (EC) 543/2013 and the Regulation for Energy Market Integrity and Transparency 1227/2011.
2. Channel RSCs shall record and share all necessary data to enable Channel onshore TSOs to fulfil the obligations regarding Channel ROSC Methodology, Channel Cost Sharing Methodology and article 17 of SO regulation.
3. By 12 months after approval of the Channel ROSC Methodology, Channel onshore TSOs shall submit an amendment of Article 39 listing the monitoring and reporting obligations regarding this Channel ROSC Methodology. Channel onshore TSOs shall consult Channel NRAs to elaborate on the monitoring and reporting obligations.

Article 40 Implementation

1. The Channel ROSC Methodology shall be implemented in a consistent manner with the Channel RD and CT Methodology, Channel Cost Sharing Methodology, CGMM and the CSAM.
2. The implementation of the Channel ROSC Methodology shall consider development, testing and implementation of the IT tools, systems and procedures required to support the Channel ROSC Methodology, CGMES format included and the CSAM.
3. During the implementation of the Channel ROSC Methodology, the Channel onshore TSOs with the support of Channel RSCs shall jointly define the timeline of each step of the day-ahead and intraday regional operational security coordination, in accordance with article 45 of the CSAM and with the methodology in accordance with article 70 of SO Regulation. The timings shall be published on the ENTSO-E website.
4. The Channel onshore TSOs and Channel RSCs shall define and implement a target solution in line with the provisions of this Channel ROSC methodology and taking into account the cross-regional common functions and tools needed for a secure and efficient system operational planning in accordance with article 40 of CSAM.
5. Channel onshore TSOs and Channel RSCs shall consider the following steps for the implementation of this target solution:
 - a. High level business solution consisting among others on identification of the contractual needs between Channel onshore TSOs and Channel RSCs, drafting of the business process, performing the gap analysis with the current situation,

-
- screening the market for potential solution to fill the gaps and drafting related business, IT and service level requirements for tools and hardware and determining the acceptance criteria for validating the accuracy and robustness of the solution;
- b. Tendering consisting in preparing and performing the selection and contracting of the vendors for the different tools and hardware solution identified in the step 5(a);
 - c. Development of the solution including the negotiation of performance requirements, functional acceptance test, site acceptance test and user acceptance test;
 - d. Experimentation of the solution by Channel onshore TSOs and Channel RSCs experts and key users aiming at tuning the different parameters to ensure accuracy and robustness of the solution towards the acceptance criteria defined in the step 4(a);
 - e. Parallel operational run where Channel onshore TSOs and Channel RSCs will train their operators and perform operational runs in parallel with the existing operational processes to assess the accuracy and robustness of the solution towards the acceptance criteria defined in step 5(a);
 - f. Operational go-live where the solution will replace the existing operational processes.
6. Channel onshore TSOs and Channel RSCs shall respect the following maximum timing (Time of Implementation, hereafter "TI") for the different implementation steps defined in the paragraph 2:
- g. Step 5(a) shall be achieved at the latest at T_{I1} equals to $T_{I0} + 12$ months, where T_{I0} is the date of approval of the Channel ROSC methodology;
 - h. Step 5(b) shall be achieved at the latest at T_{I2} equals to $T_{I1} +$ an estimation of 12 months;
 - i. Step 5(c) shall be achieved at the latest at T_{I3} equals to $T_{I2} + 18$ months;
 - j. Step 5(d) shall be achieved at the latest at T_{I4} equals to $T_{I3} + 6$ months;
 - k. Steps 5(e) shall be achieved at the latest at T_{I5} equals $T_{I4} + 6$ months;
 - l. Step 5(f) shall be achieved at the latest at T_{I6} equals to $T_{I5} + 1$ months.
7. At the end of the step 5(b), Channel onshore TSOs with the support of Channel RSCs shall issue an amendment of the Channel ROSC methodology reviewing the steps and the maximum timings of 5(c), 5(d), 5(e) and 5(f) considering the contractual agreements with selected vendors.
8. In parallel to the implementation of the target solution in accordance with paragraph 1 to paragraph 6 and with an estimated time of 24 months after the approval of the ROSC Methodology, the Channel RSCs with the support of Channel onshore TSOs, shall develop and implement a stepwise approach considering an interim solution. This approach will consider the following conditions:
- a. Improvement of the level of coordination in the existing operational processes and of the platforms and tool allowing the centralisation of relevant functions operated by Channel RSCs;
 - b. Improvement shall be based on the provisions of the Channel ROSC Methodology and shall respect the specific acceptance criteria that be defined for the interim solution;
9. In case the stepwise approach contains an interim solution,
- a. It shall be faster implemented than the target solution;
 - b. The Implementation shall not delay the implementation of the target solution;
 - c. The Implementation shall require reasonable efforts from Channel onshore TSOs and Channel RSCs.

10. Within 12 months after the approval of the Channel ROSC Methodology, Channel onshore TSOs with the support of Channel RSCs shall submit an amendment of the Channel ROSC methodology to amend the implementation plan with the description of the stepwise approach resulting from the paragraph 8 and 9.

TITLE 7 ALLOCATION OF TASKS BY CHANNEL RSCS

Article 41 Appointment of RSCs and delegation of tasks to Channel RSCs

1. Channel onshore TSOs appoint CORESO and TSCNET as RSCs that will perform the tasks listed in article 77 (3) of SO Regulation in the Channel CCR.
2. CORESO and TSCNET will perform the tasks listed in article 77(3) of SO Regulation in the Channel CCR for all Channel onshore TSOs in a transparent and non-discriminatory manner.
3. In accordance with article 77(3) of SO Regulation all Channel onshore TSOs delegate the following tasks to CORESO and TSCNET:
 - a. ROSC in accordance with SO Regulation article 78 in order to support Channel onshore TSOs to fulfil their obligations for the year-ahead, day-ahead and intraday timeframes in accordance with articles 34(3), 72 and 74 of SO Regulation;
 - b. Building of CGM in accordance with article 79 of SO Regulation;
 - c. Regional outage coordination in accordance with article 80 of SO Regulation, in order to support Channel onshore TSOs to fulfil their obligations in articles 98 and 100 of SO Regulation;
 - d. Regional adequacy assessment in accordance with article 81 of SO Regulation in order to support Channel onshore TSOs to fulfil their obligations under article 107 of SO Regulation.

Article 42 Allocation of tasks between Channel RSCs

1. CORESO and TSCNET carry out the task for ROSC in accordance with article 78 of SO Regulation on a rotational basis over a pre-determined period as defined in paragraph 2.
2. The rotational basis assumes that CORESO and TSCNET will rotate the roles of Leading and Backup Channel RSC over pre-determined periods. The Leading Channel RSC is responsible and accountable for the effective and efficient execution of the ROSC in accordance with the article 78 of SO Regulation over a pre-determined period. The Backup Channel RSC is responsible for supporting the Leading Channel RSC to ensure the effectiveness of the ROSC process for all Channel onshore TSOs. This support can be either requested by the Leading Channel RSC or suggested by the Backup Channel RSC.
3. CORESO and TSCNET carry out the task of CGM building on a rotational basis over a pre-determined period in accordance with article 20 of CGMM and with Article 79 of SO Regulation.
4. TSCNET carry out the task of regional outage coordination in accordance with article 80 of SO Regulation.
5. CORESO carry out the task of regional adequacy assessment in accordance with article 81 of SO Regulation.
6. The organization of the regional outage coordination task and of the regional adequacy assessment task in (4) and (5) may be amended in accordance with Article 43 and Article 44.

Article 43 Efficiency and effectiveness of the allocation of tasks between Channel RSCs

1. CORESO and TSCNET shall monitor the effectiveness and efficiency of the allocation of the tasks for which they are responsible and, where applicable, the rotation of those tasks and their operational performance on a yearly basis in the scope of preparation of the annual reports on regional coordination assessment according to article 17 of SO Regulation.
2. CORESO and TSCNET shall agree on clear and specific performance indicators with Channel onshore TSOs to perform the tasks mentioned in Articles 41 and 42 and to be monitored and reported in accordance with Article 39 (3).
3. CORESO and TSCNET will ensure, in consultation with the Channel onshore TSOs, transparency and interoperability of all processes and the associated data within the operational tasks mentioned in this methodology.
4. CORESO and TSCNET shall assess interoperability issues and propose changes aiming at improving effectiveness and efficiency in the system operation coordination.

Article 44 Coordination and decision-making process

1. The Leading Channel RSC with the support of the back-up RSC will ensure the coordination with all Channel onshore TSOs.
2. RSCs shall cooperate in good faith and shall seek to adopt a fair and loyal treatment of the other Parties concerned.
3. RSCs will implement the provision of the tasks in close consultation and cooperation with the Channel onshore TSOs.
4. RSCs and Channel onshore TSOs will establish a contractual framework for the implementation of this methodology.

Article 45 Rules concerning governance and operation of Channel RSCs

1. The security of supply shall be the responsibility of each of the Channel onshore TSOs according to national laws and regulations. The responsibility for secure system operation and any decision taken based on services from CORESO and TSCNET shall remain with the Channel onshore TSOs. Governance rules shall be further defined and agreed by Channel TSOs and Channel RSCs in accordance with Article 40 (5) (a) and within the timescales defined in Article 40 (6) (a).
2. For the avoidance of doubt, these rules do not replace any provision of national or European law that may apply to any of the Channel onshore TSOs. The provisions of these rules shall be complementary and interpreted in accordance with the applicable regulations. In case of contradictions between these rules and the applicable laws and regulations, the provisions of these rules shall be amended accordingly.
3. Any dispute between the Channel RSCs and between Channel RSCs and Channel onshore TSOs arising out of or in connection with this methodology shall be settled amicably between the Parties. In case the dispute cannot be settled amicably between the Parties within 60 calendar days after having been notified hereof, the dispute shall be finally settled by an arbitration process.
4. CORESO and TSCNET shall agree on a contractual framework defining the rules for operation of Channel RSCs and the liability between Channel RSCs.

TITLE 8 FINAL PROVISIONS

Article 46 Publication of this Proposal

1. Upon approval by the competent regulatory authorities, each Channel onshore TSO shall publish this Channel ROSC Methodology on the internet in accordance with article 8 (1) of SO Regulation.

Article 47 Language

1. The reference language for this Channel ROSC Methodology shall be English. For the avoidance of doubt, when Channel onshore TSOs need to translate this Channel ROSC Methodology into their national language(s), in the event of inconsistencies between the English version published by Channel onshore TSOs in accordance with article 8 (1) of SO Regulation and any version in another language, the relevant Channel onshore TSOs shall, in accordance with national legislation be obliged to dispel any inconsistencies by providing a revised translation of this Channel ROSC Methodology to their relevant national regulatory authorities.

Explanatory document to the Channel
Capacity Calculation Region methodology for
common provisions for Regional Operational
Security Coordination in accordance with
Article 76 of Commission Regulation (EU)
2017/1485 of 2 August 2017

“Explanatory Note”

21 December 2019

Disclaimer:

This document is released on behalf of the transmission system operators (“TSOs”) of the Capacity Calculation Region Channel solely for the purpose of providing additional information on the methodology for common provisions for regional operational security coordination in accordance with Article 76 of Commission Regulation (EU) 2017/1485 of 2 August 2017 establishing a guideline on system operations guideline (“SO Regulation”).

TABLE OF CONTENTS

| | |
|---|----|
| Introduction | 4 |
| 1. General Provisions | 5 |
| 1.1 Subject matter and scope | 5 |
| 1.2 Constraints | 5 |
| 2. Regional Operational Security Coordination | 6 |
| 3. Definition and determination of CHANNEL XNEs, XRAs, constraints and contingencies .. | 7 |
| 3.1 Secured and scanned elements | 8 |
| 3.2 Classification of remedial actions | 10 |
| 3.3 Cross-border relevance of remedial actions | 11 |
| 3.3.1 Qualitative assessment of XRAs | 11 |
| 3.3.2 Quantitative assessment of XRAs | 11 |
| 3.4 Contingency list | 13 |
| 4. Coordinated regional operational security analysis process | 14 |
| 4.1 Preparation | 14 |
| 4.2 Coordination | 14 |
| 4.2.1. General provisions of coordination process | 14 |
| 4.2.2. Power flow and security analysis | 15 |
| 4.2.3. Optimisation of remedial actions | 15 |
| 4.2.4. Time coupled optimisation | 17 |
| 4.2.5. Relieving operational security limit violations with balanced RAs | 17 |
| 4.2.6. Avoid additional violations of operational security limits on secured and scanned elements | 18 |
| 4.2.7. Minimise incurred costs | 18 |
| 4.2.8. RA effectivity | 18 |
| 4.2.9. Robustness | 19 |
| 4.2.10 Coordination of RAs | 20 |
| 4.2.11. Inter-CCR coordination | 21 |
| 4.3 Validation | 21 |
| 4.3.1. Outcome of validation | 21 |
| 4.4. Implementation of remedial actions | 22 |
| 4.4.1. Activation of remedial actions | 22 |
| 4.4.2. Consideration of remedial actions in next IGM | 22 |
| 4.4.3. Fast activation process | 22 |
| 5. implementation | 23 |
| 5.1. Monitoring | 23 |
| 5.2 Implementation | 23 |
| 6. Allocation of tasks by RSCs | 24 |

| | |
|--|----|
| 6.1 Appointment of RSCs and delegation of tasks to RSCs..... | 25 |
| 6.2 Allocation of tasks between RSCs | 25 |
| 6.3 Assessment of the effectiveness and efficiency | 26 |
| 6.4 Decision-making process and governance | 27 |
| Appendix 1: Efficiency and Effectiveness Assessment..... | 28 |
| 1. Executive Summary | 29 |
| 1.1 Advantages of the Rotational Operating Model..... | 29 |
| 2. Introduction. High level explanation of operating models..... | 30 |
| 2.1 Rotational Operating Model | 30 |
| 2.2 Fully Rotational Operating Model..... | 31 |
| 2.3 Splitting Tasks | 31 |
| 3. Comparison of the operating models..... | 32 |
| 3.1 Resourcing and high-level cost assessment | 32 |
| 3.1.1 Operational arrangement with Rotational Model | 33 |
| 3.1.2 Operational arrangement with Fully Rotational Model..... | 34 |
| 3.1.3 Operational arrangement if RSCs split tasks..... | 35 |
| 3.2 Expertise | 35 |
| 3.3 Resilience..... | 36 |
| 3.4 Business change | 39 |

INTRODUCTION

In accordance with Article 76 of Commission Regulation (EU) 2017/1485 of 2 August 2017 establishing a guideline on system operations (hereafter referred to as the "SO Regulation") the Channel Transmission System Operators (hereafter referred to as "Channel TSOs") submitted the Common Methodology for Regional Operational Security Coordination for the Channel Capacity Calculation Region (hereafter referred to as "CCR") to Channel NRAs. This methodology aims at the day-ahead and intraday regional operational security coordination within the Channel CCR.

The aim of this explanatory note is to provide additional information with regard to the Methodology for Regional Operational Security Coordination for the Channel CCR (hereafter referred to as "Channel ROSC Methodology"). In particular, it provides insight on the whole process chain defined in Channel ROSC Methodology, from the preparation of input data to the optimisation and implementation of Remedial Actions. This paper considers the main elements of the relevant legal framework (i.e. SO Regulation, CACM Regulation and EB guideline), and is provided to gain additional insight on the methodology only.

1. GENERAL PROVISIONS

1.1 Subject matter and scope

The Channel onshore TSO principle has been introduced in order to differentiate TSOs in charge of a control block area from Channel TSOs in charge of an interconnector only. Goal of this methodology is to make as efficient as possible the Coordination of Remedial Actions to relieve operational security limit violations, especially on current violations.

As long as interconnectors are composed of HVDC links they are not impacted by a Remedial Action which may be applied in their neighbouring network. Consequently interconnectors are not concerned by the scope of this methodology.

Regarding their Remedial Action contribution, the role of the interconnector is already described in the Channel RDCT Methodology pursuant to Art.35 of CACM.

1.2 Constraints

Different kinds of constraints are mentioned in the Channel ROSC Methodology.

- Operational security constraints are most commonly current, short-circuit, voltage or stability constraints.

The Channel ROSC Methodology shall detect if current limits in N-situation or after occurrence of a contingency are violated. If this is the case, there is a need to prepare and activate a remedial action in order to respect those current limits. For the detection of other constraints, such as voltage violations, violations of short-circuit current limits or violations of stability limits, each Channel onshore TSO should perform local assessment and long-term operational security analysis in accordance with articles 31, 38 and 73 of SO Regulation. Channel onshore TSOs will deal with these constraints, thanks to the definition of system constraints or/and local security assessment.

- Constraints on remedial actions: Constraints related to all aspects required to be taken into account when using RAs in accordance with article 20(1) SO Regulation and classified as following:
 - Technical constraints are all the rules that a power source has to comply with for technical reasons such as preparation period, ramping period, full activation time, minimum and maximum power output, deactivation period, minimum and maximum duration of delivery period, limit values for voltage, current or power, etc. As consequence, for Redispatching & Countertrading, at least the following technical constraints are considered:
 - i. Minimum and maximum redispatch values (MW)
 - ii. Maximum power increase and decrease gradient (MW/h)
 - iii. Minimum up and down time
 - iv. Lead and Lag time
 - v. Start-up and Shut down allowed
 - vi. constraints for storage
 - Operational constraints means all the operational conditions and usage rules taking into account the timings to operate the grid (for example, an operator can only activate a limited number of remedial actions in a given period) and avoid a premature use of the

- network elements (limitation of the frequency of switching of one breaker, synchronized change of PST taps).
- Procedural constraints mean all the timing constraints due to local or regional processes e.g.:
 - i. timings T0 to T5 according to article 45 CSAM to be respected during DA CROSA;
 - ii. Maximal time to perform the remedial actions optimisation
 - iii. time to perform a local security analysis
 - iv. Timings to request a Remedial Action from a non-Channel TSO, etc.
 - Legal constraints mean the legal requirements stated in national laws regarding the priority of activation of remedial actions. For example, some countries can legally not downregulate RES even though it is less expensive or more efficient to solve a given flow constraint.
- System Constraints are additional optimisation constraints added by Channel onshore TSOs, expressed as flow limitation on one or a sum of Secured and/or Scanned elements and necessary to substitutional respect stability limits or operational security limits other than current limits. For example, to prevent stability violations, a TSO could limit the overall amount of power flow on three network elements (for example 1000 MW) even though the sum of the capacity of these three elements is above 1000 MW. Channel onshore TSOs specifying such system constraints shall share transparently with Channel RSCs and TSOs the information justifying their application. *Rate of Change of Frequency (ROCOF), Commutation Failure, Voltage Stability and Sub-Synchronous Resonance are also part of system constraints that might be specified by Channel onshore TSOs to Channel RSCs.*

2. REGIONAL OPERATIONAL SECURITY COORDINATION

As illustrated in figure 1, the Channel Regional Operational Security Coordination (ROSC), that shall be executed for each hour of the target day, is composed of the following activities:

- One day-ahead and several intraday Coordinated Regional Operational Security Assessment (hereafter referred to as 'CROSA').
- Intraday CROSA shall be performed at least three times in intraday timeframe in accordance with article 24 of CSAM. Each CROSA shall consist of:
 - i. Preparation phase;
 - ii. Coordination phase;
 - iii. Validation phase.
- The implementation of the Agreed Remedial Actions (RAs) in the subsequent individual grid models (IGMs) and activation of the Ordered RAs.
- Modification of an Ordered RA or activation of a new RA might be considered following the fast activation process.

The different steps of the DA CROSA process will be performed respecting the timings T0 till T5 defined in accordance with the Methodology for coordinating operational security analysis in accordance with article 75 of SO Regulation (hereafter referred to as 'CSAM').

A minimum of three ID CROSA shall be performed considering the three mandatory CGMs which have to be built for 00h00, 08h00 and 16h00 according to CGMM.

More details about the preparation and coordination phases are given in the relevant chapters of this Explanatory Note.

The validation phase shall mainly consist of the formalization, communication, reporting and archiving of the CROSA results. In DA, in line with the Methodology for coordinating operational security analysis in accordance with article 75 of SO Regulation (hereafter referred to as 'CSA'), this formalization shall take place through a pan-European conference with representatives of all RSCs and TSOs.

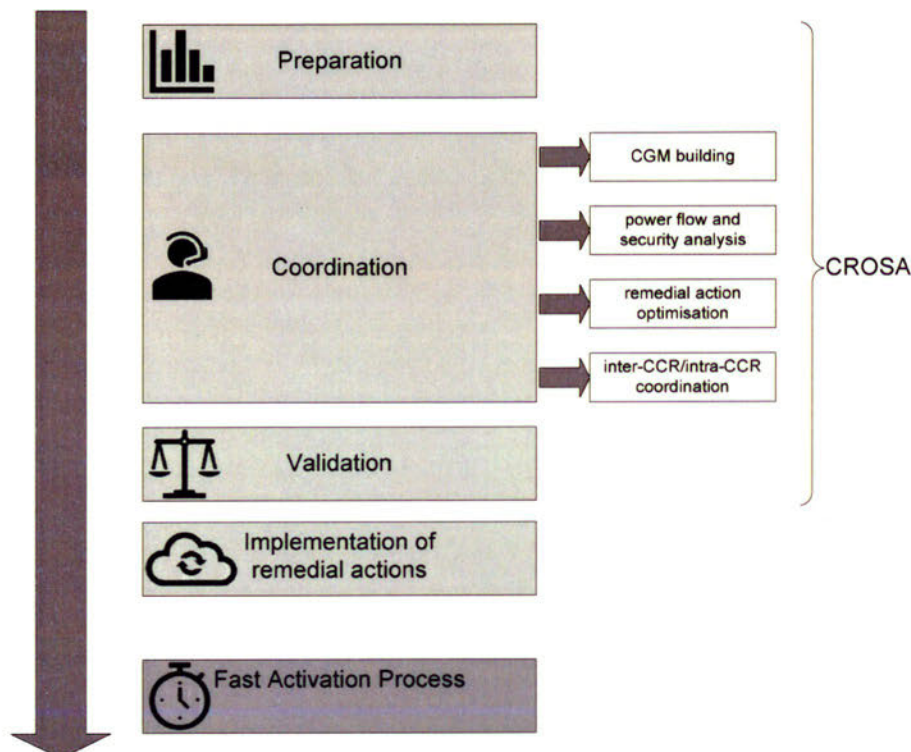

Figure 1: Overview Coordinated Regional Operational Security Assessment (CROSA) process

On top of the ROSC process, Channel onshore TSOs with Channel RSCs shall perform intraday regional security analysis ('ID RSA'). The goal of the ID RSA is to provide Channel onshore TSOs each hour of the day with the latest information about the loading of the grid and previously undetected violations of operational security limits, which may serve as a trigger for a fast activation process.

3. DEFINITION AND DETERMINATION OF CHANNEL XNES, XRAS, CONSTRAINTS AND CONTINGENCIES

According to article 15 of CSAM, *cross-border relevant network elements (XNEs) shall be all critical network elements ('CNEs') and other network elements above the voltage level defined by TSOs,*

except for those elements for which all TSOs in a CCR agree that they are not cross-border relevant for the concerned CCR and may therefore be excluded.

3.1 Secured and scanned elements

In order to harmonize definitions used across CCRs and to use same terminology in future processes, ENTSO-E proposed to define and use the following wording in all regional ROSC methodologies:

- o A **Secured element** is an assessed element on which, when violations of an operational security limit are identified during the regional or cross-regional security analysis, remedial actions needed to relieve these violations shall be identified.
- o A **Scanned element** is an assessed element on which the electrical state (at least flows) may be computed and may be subject to an observation rule during the regional security analysis process. Such observation rule can be for example to avoid increasing a constraint or to avoid creating a constraint on this element, as a result of the design of the remedial actions needed to relieve violations on the secured elements.

Having this in mind, Channel onshore TSOs decided that **secured elements are the elements identified as cross-border relevant network elements (XNEs)** in accordance with CSAM within the Channel CCR.

Channel onshore TSOs include network elements in their IGMs in line with the CGMM and CSAM, which include network elements of different voltage levels (including <220 kV). Most relevant network elements for the CROSA process to be defined as Secured elements are the network elements on 220 kV, 275 kV, 380 and 400 kV level, as these elements are used to facilitate the energy exchanges between bidding zones within the European energy system. Yet, it has to be noted that in some countries the grid of a voltage level lower than 220kV is not operated by the TSOs but by distribution system operators. Although in accordance with Article 6 of CGMM, grid elements of a voltage level lower than 220 kV may be included in the grid model, this does not mean that TSOs have to actively relieve congestions in these grids during the CROSA. It is rather meant to ensure that a RA used for the High Voltage grid will not lead to (further) congestions in the lower voltage grids and determine the impact of these grids on the 220, 275 kV, 380 kV and 400 kV grids. This will be achieved by introducing scanned elements into the ROSC methodology.

In contrast, considering only elements with a voltage level equal or higher than 380kV as XNEs, would mean that 220kV elements which have cross-border relevance would not be considered in the regional or cross-regional process. Having this in mind, Channel onshore TSOs decided to consider all elements with voltage level equal or higher than 220kV as XNEs (Channel XNEs) and decided to define criteria for which certain elements can be discarded as XNE.

If one of the following criteria is fulfilled, Channel onshore TSOs shall have the right to exclude elements from the set of secured elements:

- a) Element is a power plant line: e.g. line connecting a substation to which only generation is connected to the meshed grid and is therefore not relevant for cross-regional processes.
- b) Element is a radial line: e.g. elements operated in radial topology; connected to a substation that is not connected to any other substation at a voltage level higher or equal than 220kV.

- c) Element is connected to a DSO grid: e.g. elements operated by DSOs at a voltage level equal or higher than 220kV that have distribution character.
- d) Element is a transformer with the secondary voltage side lower than 220kV e.g. transformers connected to DSO grids.

The following figure 2 shows which elements (highlighted in yellow) can be discarded from the set of secured elements in accordance with the provisions explained above.

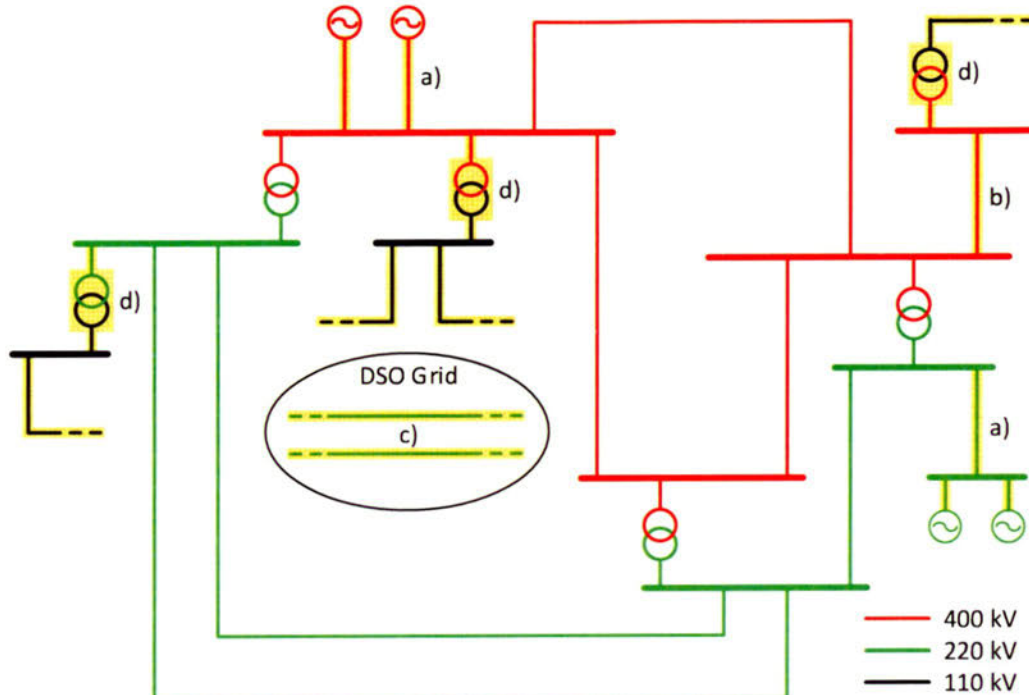

Figure 2: Elements (highlighted in yellow) which can be discarded from the set of Channel XNEs

- In addition to these criteria, any element can be discarded from the set of secured elements, when a common agreement among Channel onshore TSOs is reached. This could be the case, if a part of the grid is almost not influenced trans-regionally.

TSOs which are part of more than one CCR shall have the right to discard any of their elements from the set of secured elements which are regarded as XNE in another CCR.

As suggested by ENTSO-E, Channel onshore TSOs define scanned elements as set of elements on which the CROSA shall not create new operational security limits violations or worsen any existing violation. Such elements can be elements which are discarded from the set of secured elements with voltage level lower than 220kV. In the latter case, these elements have to be included in the IGM and TSOs shall provide justification of their inclusion in the set of scanned elements (e.g. elements influenced by RA used to solve constraints on secured elements). Such an inclusion must be compliant with the CGMM.

Channel onshore TSOs shall have the right to update the lists of secured and scanned elements at any time (e.g. due to commissioning of a new element or seasonal changes) considering that:

- Any element with a voltage level equal or higher than 220kV is regarded as secured element by default and therefore any new element at such a voltage level can be included in this list of secured elements.
- Discarding an element from the list of secured elements is subject to common agreement by Channel onshore TSOs, except for those elements, that fulfil one of the criteria defined in this chapter.
- Any discarded element from the list of secured elements can be included in the list of scanned elements, but it is not mandatory.
- Each Channel onshore TSO shall have the right to move any elements it operates with a voltage level equal or higher than 220kV from the list of scanned elements to the list of secured elements.
- Each TSO shall have the right to include any new element with a voltage level lower than 220kV in the list of scanned elements providing justification for its inclusion. Such elements have to be modelled in IGM.

Channel onshore TSOs shall have the right at any time to exclude any element from the set of scanned elements. Channel onshore TSOs shall update the secured elements list and scanned elements list when necessary and inform the Channel RSC about the change. Both lists shall be reassessed by each Channel onshore TSO at least once a year.

Lists of secured and scanned elements will be made available before each CROSA process.

Each Channel onshore TSO shall have the right to set individual thresholds for overloads for the scanned elements (e.g. 110kV line), for CROSA purposes only, reflecting the fact that TSOs are able to accept certain overloads on such elements. This could be the case, if there are for example additional RAs not explicitly modelled in the CGM, which can further relieve the violation on the scanned element.

3.2 Classification of remedial actions

Each Channel onshore TSO has to prepare a list of remedial actions which can be used to relieve at least violation of the Channel onshore TSO's current limits. Channel onshore TSOs shall design these RAs taking into account the categories defined in article 22 of the SO Regulation but not limited to them.

Within one month, after the set of secured elements has been defined, Channel onshore TSOs shall share with Channel RSCs all potential RAs.

In accordance with article 14(2) of CSAM, a RA can be designed as a single action or a combination (set) of actions as listed in article 22 of the SO Regulation. If a RA consists of multiple actions, it still should be treated as one.

When designing a RA, Channel onshore TSOs have to include all the relevant information such as availability timeframe, activation time, costs (for costly RAs) and all constraints limiting its usage. In accordance with article 16 of CSAM for each RA shall be identified its cross-border relevance. How to identify the cross-border relevant remedial actions has been introduced in Articles 10, 11 and 13 of this Methodology.

3.3 Cross-border relevance of remedial actions

The CSA methodology defines a cross-border remedial action (XRA) as a RA identified as cross-border relevant and which needs to be applied in a coordinated way. The cross-border relevance of a RA shall be evaluated qualitatively or quantitatively for at least each cross-border relevant network element and each contingency.

Considering the definition of Channel XNEs, it is obvious that some RAs will only have a relevant impact on XNEs located in the same control area and will de facto only affect its connecting TSO. Nevertheless, these remedial actions will still be named "cross-border relevant" and flagged as XRAs. However, during the fast activation process, the activation of such XRA by the connecting TSO will not be subject to further coordination.

3.3.1 Qualitative assessment of XRAs

Channel onshore TSOs shall aim at agreeing on a qualitative approach to determine RAs that are deemed cross-border relevant and to identify corresponding TSOs affected by those RAs. This process consists of the following steps:

- In order to assess if a RA is cross-border relevant, each Channel onshore TSO shall assess the impact of the RA on its control area.
 - This assessment can be based on operational experience, but it is not limited to it;
- In order to assess the cross-border relevance of the RA, the RA Connecting TSO shall assess the impact on the control area of other TSOs;
 - It is needed to assess relevance of the RA on the grid of other TSOs and on its own grid in order to compare the results among TSOs, as TSOs might have different views on certain RAs. This can be expected when quantities for redispatch or tap positions of PSTs will be assessed.
- If the RAs are quantifiable such as redispatching, countertrading, change of set point on HVDC systems or change of taps on phase-shifting transformers, the quantity above which this RA is deemed cross-border relevant on the grid of other TSOs and its own grid has to be specified.
 - In case of PST number of TAPs or change in the flow can be specified
 - In case of redispatching, the amount for internal redispatching and the amount per TSO/TSO border shall be specified.
 - In case of HVDC change from set point shall be specified.
- Channel onshore TSOs will share the results of the assessment and provide justifications to connecting TSOs why RAs have been selected as relevant.
- If common agreement is reached among Channel onshore TSOs, then RA is defined as cross-border relevant and affected TSOs will be identified.
- If a RA is not proposed as cross-border relevant by any Channel onshore TSO, it is considered as non-cross-border relevant.
- If a RA is identified as cross-border relevant only for the RA Connecting TSO, this TSO shall be considered as the only XRA affected TSO.

3.3.2 Quantitative assessment of XRAs

In case that Channel onshore TSOs cannot agree on a qualitative approach for a certain RA, a quantitative approach as described in article 15 (4) of CSAM shall be used:

"In case of a quantitative approach, the cross-border relevance of remedial actions shall be assessed with the remedial action influence factor. The remedial action influence factor shall be calculated for at least each cross-border relevant network element and each contingency (for example each 'XNEC') as a simulated flow deviation on a XNEC resulting from the simulated application of a remedial action normalised by the permanent admissible load of the associated XNE."

The influence factor is calculated as follows:

$$IF_{RA} = \text{MAX}_{\forall s, \forall x \in X, \forall c \in C} \left(\frac{P_{s,RA}^{x,c} - P_s^x}{PATL^{s,x}} \cdot 100 \right)$$

Where

IF_{RA} : Influence factor of a RA on the TSO's control area (in %);

s: Scenarios;

x: XNE connected inside TSO's control area where the active power difference is observed;

X: set of XNEs connected inside TSO's control area for which the assessment is performed

c: Contingency;

C: set of contingencies to be assessed;

$P_{s,RA}^{x,c}$: Active power flow or current through the XNE in scenario s with contingency c and RA applied;

$P_s^{x,c}$: Active power flow or current through the XNE in scenario s with contingency c;

$PATL^{s,x}$: Permanently Admissible Transmission Loading is the loading in A (MW or MVA) that can be accepted by XNE in the scenario s for an unlimited duration

Channel onshore TSOs shall use the common grid models established in accordance with article 67 of the SO Regulation when computing remedial action influence factor.

If a RA consists of a combination of actions, its cross-border relevance shall be assessed for the effect of the combination. All remedial actions which have influence factor greater than the threshold defined in article 15 (5)¹ of CSAM shall be considered as cross-border relevant, otherwise RAs shall be considered as non-cross-border relevant. All Channel onshore TSOs that have at least one affected XNEC for which the remedial action influence factor is greater than the threshold shall be considered as XRA affected TSOs,

TSOs shall delegate tasks described above to their respective Channel RSCs.

- Once the assessment of remedial actions have been performed, the list of cross-border relevant remedial actions together with the affected TSOs will be shared among Channel onshore TSOs and will be provided to Channel RSCs.
- Reassessment of the list of cross-border relevant RAs shall be done on a yearly basis. Nevertheless, each Channel onshore TSO shall have the right to request an additional assessment of a RA providing justification for such a request to the RA Connecting TSO and respective Channel RSCs.

In the CROSA process step it can only be analysed which TSOs are affected by the application of the determined whole solution by determining the effect of the overall solution on the XNEC of each TSO.

¹ 5%

If the influence factor of the overall CROSA solution on given XNEC, calculated in the same way as for determination of XRAs, is greater than the threshold defined in article 15 (5) of CSAM, than the XNEC is considered affected. Channel onshore TSO which have at least one affected XNEC will be than considered as CROSA affected TSO. All CROSA affected TSOs and RAs connecting TSOs participate in the further coordination steps.

The determination of the cross-border relevance of RAs in the process of fast activation is different. Due to the manual nature of this process and in most cases only corrective actions in an existing result, for these measures a clear assignment of individual measures also in terms of redispatching and countertrading can be done. In order to determine the cross-border relevance of these measures, use can be made of the process described in Articles 10-12 of the Channel ROSC methodology. The TSOs first determine ex-ante usual RD & CT measures and determine their cross-border relevance for these and all non-costly RAs based on their experience. For RD & CT, the determination for each selected combination could be done per MW, for PSTs per tap position and for topological measures based on their binary state (qualitative approach).

The resulting list will be harmonized with all other TSOs in accordance with Article 11 of the Channel ROSC. In the case of a lack of agreement, a quantitative determination as in Article 12 of Channel ROSC will be applied. If RAs or combinations of RAs are selected in the context of the Fast Activation Process and were not determined ex-ante (e.g. very unusual ones), it is to be determined by the activating TSO to what extent the measures have an impact on other TSOs by means of appropriate tools based on load flow calculations and coordinate with these TSOs prior to ordering the measures. The task of ad hoc determination of the cross-border relevance of RAs can be transferred to the RSC.

3.4 Contingency list

When performing operational security analyses, each TSO shall, in the N-Situation, simulate each contingency from its "contingency list" and verify that the operational security limits in the (N-1) situation are not exceeded in its control area (Art.72.3 SO GL). Such contingency list, in a highly meshed network, shall include all the internal (inside the TSO's control area) and external (outside TSO's control area) contingencies that can endanger the operational security of the TSO's control area (Art.33 SO GL).

This list should be established based on provisions defined in CSAM (article 10 and related articles). Each Channel onshore TSO should prepare a contingency list only with elements relevant for Channel CCR and used in Channel CROSA process. That means elements located in the TSO's control area which are assigned to different CCR should not be placed on the contingency list provided to Channel RSCs unless contingency on that element can endanger the operational security limits on the secured or scanned elements defined in Channel CCR.

Such established contingency list should be made available to both Channel RSCs and Channel onshore TSOs during the preparation phase and should be updated by Channel onshore TSOs when relevant, especially when the conditions are met to apply temporary occurrence increasing factors for exceptional contingencies or when a significant change in the grid occurred. RSCs shall always use the latest Contingency lists shared by the Channel onshore TSOs, which means that it is up to

Channel onshore TSOs to decide if they want to send the contingency list for each CSA run or only if there is an update of the list.

4. COORDINATED REGIONAL OPERATIONAL SECURITY ANALYSIS PROCESS

4.1 Preparation

The preparation phase aims at gathering all relevant inputs for the CROSA. Each Channel onshore TSO shall make available the following input data to Channel RSCs:

- IGMs in line with the CGM methodology, including the operational security limits for each secured or scanned element;
- Available remedial actions within his control area;
- When relevant, System Constraints;
- Secured and scanned elements;
- Contingency list

The input data shall cover all remaining hours for a relevant business day. Channel onshore TSOs shall deliver or update when required the input data respecting format and process deadlines commonly agreed during the implementation. When providing an update of the list with available RAs, Channel onshore TSOs shall re-assess their availability and consider the agreed outcome of previous optimisations in accordance with Article 16 of Channel ROSC Methodology.

When receiving any input data, the Channel RSCs shall perform a quality and consistency check aiming at identifying any format error or any inconsistency with the information contained in the IGMs. The Channel RSCs shall then report these errors to the Channel onshore TSOs to give him the opportunity to correct them prior to the coordination phase.

4.2 Coordination

4.2.1. General provisions of coordination process

The coordination run consists of the following four steps. These steps are illustrated in figure 3 and further described in the Articles 22 to 32 of the Channel ROSC Methodology.

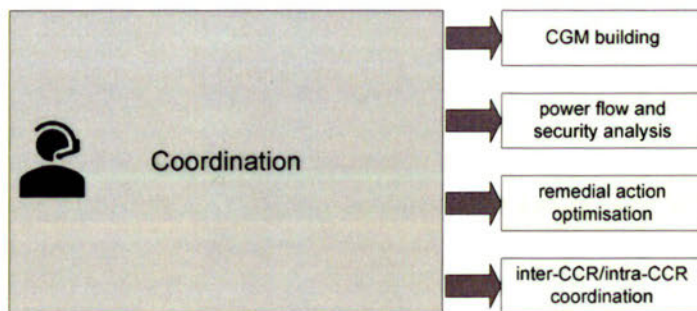

Figure 3: Overview coordination process

The day-ahead CROSA includes two of those coordination runs. There will be at least three ID CROSAs and each will include at least one coordination run. Two runs are needed in day-ahead so that the impact of every RA identified during the first run can be assessed during the 2nd run not only on lower voltage levels within Channel onshore TSOs but also by the other CCRs and non-Channel onshore TSOs.

Intra-CCR coordination describes the coordination between Channel onshore TSOs and Channel RSCs, inter-CCR coordination means the coordination between Channel onshore TSOs and RSCs with the TSOs and RSCs of other CCRs.

4.2.2. Power flow and security analysis

The validation aims at identifying input mistakes which would make the outcomes of the operational security analysis non-realistic to give Channel onshore TSOs the opportunity to correct these errors. It doesn't mean that TSOs have to perform a power flow and security analysis on their own and then compare the results to validate them.

4.2.3. Optimisation of remedial actions

An optimization of RAs has to be done in order to identify in a coordinated way the most effective and economically efficient RAs. In order to minimise the complexity for the optimization and considering violations of short-circuit current limits, voltage limits and stability limits are more local issues, the described optimization will aim at solving current operational violations while violations of short-circuit current limits, voltage limits and stability limits shall be tackled by TSOs local security assessment as specified in article 25 (3) of Channel ROSC Methodology or by adding further system constraints. The results of the violations of operational security limits resulting from these TSOs local assessments which have impact on the status of available XRAs will be communicated to other Channel onshore TSOs and Channel RSCs.

Main goal of the optimisation process and part of the CROSA is that each TSO shall maintain current (or translated power flows) through XNEs within the operational security limits defined when the system is in normal state and after the occurrence of a contingency.

The optimization should be able to identify RAs relevant for congestion management among the categories of remedial actions as described in Article 22 of SO Guideline but not limiting to them. To facilitate the implementation of the optimization solution, the following RAs shall be taken into account:

- actively impact power flows by means of:
 - i. tap changes of the power transformers;
 - ii. tap changes of the phase-shifting transformers (PSTs);
 - iii. modifying topologies;
- redispatch transmission or distribution-connected system users within the TSO's control area, between two or more TSOs;
- countertrade between two or more bidding zones;
- adjust active power flows through HVDC systems;
- modify the duration of a planned outage or return to service transmission system elements to achieve the operational availability of those transmission system elements.

When optimizing RAs, technical constraints shall be considered. For example, for topological RAs (including PST), TSOs consider a maximum number of preventive topological actions per TSO between successive hours (either by taking into account a maximum number X of preventive topological actions per TSO between successive hours. The value X depends on each TSO operational constraints or by progressively penalizing the number of actions above a threshold Y.

In order to avoid damage or too high impact on the life cycle of an electrical asset, the optimization shall consider technical flexibility:

- Regarding PST taps, the optimization shall take into account a maximum frequency of tap changes in a given time interval define by each TSO or shall aim at minimizing the frequency of tap changes.
- Regarding topological RAs, the optimization shall take into account a maximum frequency of switching per element in a given time interval defined by each TSO or shall aim at minimizing the frequency of switching.
- Maximum number of curative RAs after contingency: Because there is a maximum time to activate curative remedial actions after the occurrence of a contingency, the optimization shall consider a maximum number of curative RAs per outage. Each TSO shall specify this number according to their own risk assessment.
- Curative RA associated to specific contingency: To activate a Curative RA, the contingency causing the constraint has to be in the observability area of the RA Connecting TSO. The occurrence of the contingency is then the trigger to activate the curative RA.
- Regarding PSTs, the active power flows through PSTs may be controlled in different modes, with the goal of optimising the network capacity and ensuring security in a determined region. This is valid for PSTs owned by TSOs but also for PSTs owned by third parties, which are not controlled directly by the TSOs. The operation modes can consist of tap or active power flow target and flow range. The operation mode influences the optimisation. In case of tap target mode, the optimisation shall consider as input tap range and shall provide as output tap setpoint. In case of active power flow target mode, the optimisation shall consider as input active power range and shall provide as output active power setpoint.

Cancellation or modification of the duration of a planned outage is, for the time being, considered non-costly RA. The TSOs shall provide its availability on a voluntary basis. If TSOs provide its availability, RAs shall be accordingly taken into account during the optimization.

In accordance with article 14(2) of CSAM, a remedial action can be designed as a combination of actions. In that sense, the optimization should also take this kind of remedial actions into account.

The remaining RAs related to Article 22 of SO guideline might be considered by each TSO when performing its local assessment regarding violation of voltage, short-circuit and stability operational limits. These actions are:

- control voltage and manage reactive power by means of:
 - tap changes of the power transformers;
 - switching of the capacitors and reactors;
 - switching of the power-electronics-based devices used for voltage and reactive power management;

- instructing transmission-connected DSOs and significant grid users to block automatic voltage and reactive power control of transformers or to activate on their facilities the remedial actions set out in points (i) to (iii) if voltage deterioration jeopardises operational security or threatens to lead to a voltage collapse in a transmission system;
- requesting the change of reactive power output or voltage set point of the transmission-connected synchronous power generating modules;
- requesting the change of reactive power output of the converters of transmission-connected non-synchronous power generating modules;
- The following RAs listed in article 22 of SO Guideline will not be considered in the optimization, because they are not relevant to identify the most effective and economically efficient RAs for congestion management:
 - Inclusion of the normal or alert state manually controlled load-shedding;
 - Activation of frequency deviation management procedures;
 - Curtailment, pursuant to Article 16(2) of Regulation (EC) No 714/2009, the already allocated cross-zonal capacity in an emergency situation where using that capacity endangers operational security, all TSOs at a given interconnector agree to such adjustment, and re-dispatching or countertrading is not possible;
 - Re-calculation of day-ahead and intraday cross-zonal capacities in accordance with CACM guideline.

4.2.4. Time coupled optimisation

Taking into account that:

- Certain remedial actions, like generation units, have a minimum up-time/runtime or down-time taking more than 1 hour;
- Electrical equipment has limitation on number of switching actions per day,
- Operators can only manage a maximum number of topological changes between hours

Only the time-coupled optimisation can lead to practical and least costly solution jointly considering all remaining hours of a day, and therefore is required.

For time-coupling optimisation, it is crucial to make use of constant identifiers for all relevant grid elements (as described in CGMM).

Depending on the timeframe the time-coupled optimisation taking into account technical, organisational and legal constraints should be performed for the 24h in day-ahead timeframe and for the remaining hours till the end of the day in the intraday timeframes. In order to avoid dramatic changes and mitigate too high influence of the first hour(s), the optimiser should consider the result of the previous hours (e.g. from the previous day).

4.2.5. Relieving operational security limit violations with balanced RAs

The optimisation shall identify RAs to avoid overloads on secured elements in base and contingency cases. A curative RA may be used to avoid the overload in contingency case on a secured element as long as the temporarily limit (TATL) of the element is not exceeded. The overall optimization result after application of preventive and curative RAs shall respect the permanent limits (PATL) of the secured network elements.

In order to reassess the need of the Agreed but Not Ordered RAs (ANORAs), ANORAs are removed from the CGM for the next CROSA. It allows to adjust the volume of costly measures and avoids unnecessary costs. The removed ANORAs are added to the list of available RAs before the new optimisation is performed unless those removed ANORAs are no longer available for technical reasons.

Due to the possibility of re-dispatching of generation units, the cumulated fed-in active power into the electrical grid could change. To avoid this kind of behaviour and guarantee a balance between active power generation before and after optimisation the redispatch needs to be activated in a balanced way.

In case a removed ANORA has an influence on the balance of the grid, the subsequent optimisation needs to take this into account by reasonable means and ensure that the new proposed RAs are balanced in accordance with Article 28.

4.2.6. Avoid additional violations of operational security limits on secured and scanned elements

The optimisation shall guarantee that no new operational security limits violations regarding current are created on secured and scanned elements nor existing ones are worsen. In case of scanned elements, the optimisation will take the threshold which is described in article 6 (1) of Channel ROSC into consideration.

4.2.7. Minimise incurred costs

Because all incurred costs of applied costly RAs has to be incurred by TSOs, regardless of applied payment principle (i.e. requester pays or polluter pays), as it is also required by SO guideline that the CSA outcome has to be "most effective and economically efficient", the minimisation of RAs incurred costs should be a principle of the optimisation. The most effective and efficient activation of RA is depending on the location of the overload, actual availability and location of RAs.

The total incurred costs consist of estimated costs incurred by costly RAs (e.g. redispatching and countertrading) for congestion management, i.e. the estimation of incurred costs invoiced or credited by the providers of ordered costly RAs as defined in Channel RD and CT Methodology. It may include ramping costs, costs/revenues for balancing, and where applicable start-up costs and shut-down costs where Channel onshore TSOs agree to start or stop a generating asset to solve congestions.

4.2.8. RA effectivity

With the objective to determine the most effective set of remedial actions, the Channel RAO when considering the selection of an individual costly or non-costly remedial action, shall consider the sensitivity of these actions on each of the overloaded optimized grid elements. This sensitivity factor shall be expressed in percentage of the maximum current of the concerned optimized grid elements.

For costly RA, the sensitivity of any change of power on a generating unit shall require a definition of the compensation. This will be defined during the implementation.

The objective to minimize the total cost of costly remedial action will lead to the fact that, at identical sensitivity, a less costly RA shall always be preferred to one with higher costs. But using low effective RA to solve far away congestions might also have side effects in term of grid stress and reduction of available means close to their activation. The exact ratio between cost and sensitivity might have to be tuned in order to avoid over-used of far and less sensitive non-costly remedial action just to provide limited gain in the incurred costs.

The main driver of the optimisation, as part of the CROSA process, is the security of supply by finding the most optimal set of RAs taking into account their effectivity and efficiency.

During CROSA it will be indicated if a bidding zone/TSO is affected by a RA. This is required to determine the affected TSOs and required when a RA gets rejected.

4.2.9. Robustness

In circumstances where the initial loading of secured elements is above its current limits, the result of the regional operational security coordination will lead to loadings on one or several secured elements very close to its current limits. Any variation for example of forecasts in consumption, RES production, market activities or unforeseen outages could lead again to overloads of the secured elements. In these situations, the Channel onshore TSOs must still have access to short-term potential of Remedial Actions to react on these overloads. Therefore, the solution of the regional operational security coordination shall not recommend additional RAs for these circumstances but shall, whenever possible, free them up in case they are needed.

As example, Redispatching in a short-term period could not be possible due to the fact, that the respective Power plant is offline and requires a too long lead time before it can be used for the demanded Redispatching. A robust solution could take this into account and finds results, where instead of one Power plant is fully used for Redispatching, two Power plants are used in each case with minimum power infeed.

A technical possibility to achieve a robust solution regarding Redispatching may be to perform a pre-run of the optimization, where the current limits of secured elements are reduced to a value smaller than 100%. Power plants which are started up for Redispatching and which cannot be re-evaluated in the next CROSA are "Must-use" Redispatching for the consecutive ordinary optimization at least with its minimum power. The consecutive ordinary optimization will use current limits without reliability margin in accordance to CSAM Article 23 (1)(a) and CSAM Article 24 (3)(a).

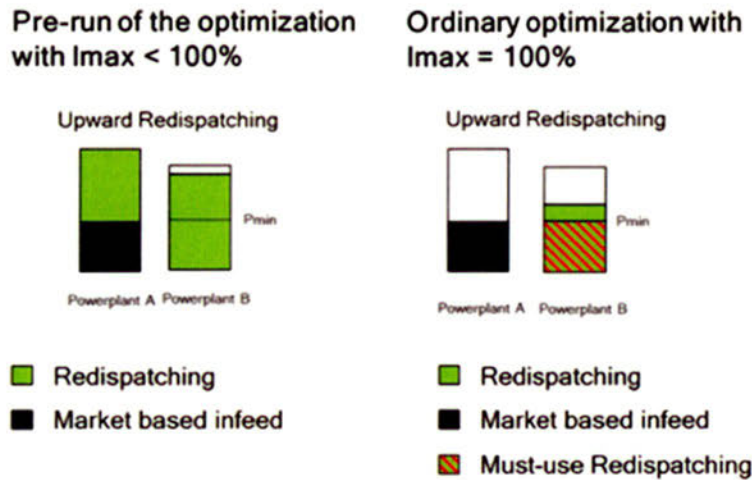
Example:

Other possibilities exist to reach this goal as among others:

- 1/ considering additional margin respecting uncertainties to monitor and solve congestions,
- 2/ ensuring that non-used RAs provide sufficient margin on highly loaded elements,
- 3/ limiting the number of used actions in function of the time horizon of computation,
- 4/ others...

During the implementation of the ROSC methodology, RSCs and TSOs will further assess and experiments the possibilities and amend the methodologies with the most appropriate solution

4.2.10 Coordination of RAs

Channel onshore TSOs are allowed to reject RAs proposed by Channel RSCs. The following list includes some examples for a required rejection of a RA:

- power plants are currently not available;
- provided input data is not correct;
- a network element trips;
- violations of voltage or stability limits identified in local assessments;
- violations of operational limits in voltage levels below 220 kV identified in local assessments.

Normally, only the RA connecting TSOs and CROSA affected TSOs (as described in p. 3.3.2) will have right to reject the CROSA solution proposed by RSC. The rejection of a RA by a TSO must not mean that the whole solution is rejected but only particular RAs. Such rejection may not imply new calculation. In case of rejection of RAs connecting and/or affected TSOs with the support of Channel RSCs shall identify and plan alternative RAs taking into account cost and efficiency to relieve the operational security limits violations.

If a Channel onshore TSO rejects a RA proposed by Channel RSCs, the reasons shall be justified, documented by the relevant Channel onshore TSO(s) and provided to Channel RSCs.

Output of coordination: As outcome of a CROSA, the list of Agreed RAs is defined. This list identified the best estimation of the RAs that will need to be used to relieve violation of flow operational security limits on Secured elements. When the foreseen time of a congestion and technical or other constraints allow so, TSOs might reassess the need to apply already Agreed RAs during ID CROSAs.

Based on updated CGM (including better load and generation forecast, unplanned outages etc.), RAO process may result in a need to increase or decrease the volume of certain RAs (such as RD, CT or PST tap change) or not using the RA at all and therefore find a more efficient and effective way to handle identified congestions. To be able to distinguish between Agreed RAs which might yet be reassessed in next ID CROSA(s) and those which cannot be reassessed, Channel onshore TSOs have developed two terms to divide between Agreed RAs which can or cannot be reassessed in next ID CROSA:

- ANORA (Agreed but Not Ordered Remedial Actions) – their activation time allows reassessment in next ID CROSA and therefore steps leading towards their activation do not have to be made. ANORA is only the best estimate of a final solution that will be activated.
- Ordered Remedial Actions – cannot be reassessed later either due to its activation time or due to necessity to relieve a congestion forecasted to happen before next ID CROSA. Therefore steps leading to ORAs activation should be made. Only Fast activation process can lead to a change in Ordered RA.

4.2.11. Inter-CCR coordination

Article 46 of CSAM states that no later than eighteen months after the adoption of the CSAM, all TSOs shall jointly issue a request for amendment of the CSAM with rules for the identification and definition of overlapping zones, overlapping XNEs, overlapping XRAs, impacting CCRs and competent RSC(s), as well as, rules for the sharing of costs of the activated overlapping XRAs, in accordance with Article 27(3).

This amendment will be the basis for Inter-CCR coordination, will be ready before the end of the implementation of the target solution for the Channel ROSC and will be agreed among all CCRs. Therefore, Channel onshore TSOs decides not to develop Inter-CCR coordination principles in the meantime because such principles will never be implemented before the CSAM amendments and Channel onshore TSOs cannot enforce such principles on other CCRs. The non-development of such principles will not delay the implementation of the Channel ROSC Methodology and in the meantime Channel onshore TSOs and Channel RSCs will apply the bilateral or multilateral agreements that already exist between Channel onshore TSOs and other CCR TSOs or between Channel RSCs and other RSCs.

4.3 Validation

4.3.1. Outcome of validation

After the validation session, Ordered RA and ANORAS are known and can be logged and implemented in the IGM in accordance with article 36.

It may happen that there are some remaining violations at the end of the validation session for several reasons, e.g.:

- the optimization didn't find enough RA to remove every violation
- during the coordination of RAs according to article 31, some RAs have been rejected for relevant reasons
- some RAs are not available anymore because of a contingency

In those situations, depending on when the violation is forecasted to happen, TSOs can propose new RAs in the set of available RAs, can look for RAs coming from others CCRs, or can launch a Fast Activation Process.

The procedure for the determination of cross-border relevant RA is largely dependent on the process step. The DA- or ID-CROSA will typically be characterized by the need to remove multiple congestions at the same time. As a result, a mix of non-costly and costly RAs can be expected, which must be understood as an overall measure to address all congestions. A clear allocation of individual measures, especially with regard to redispatching & countertrading, does not make sense.

4.4. Implementation of remedial actions

4.4.1. Activation of remedial actions

Respecting the results of last CROSA process, TSOs shall activate Agreed Remedial actions as close to real time as possible respecting their technical, operational, procedural and other constraints.

To prevent intraday market trading further worsening the congestion and mitigating the relieving effect of the RA, the available cross-border capacities shall be updated. TSOs should not reduce available cross-border capacities unless it is considered that the N-1 security of the system is endangered. If it is, then only available capacities in the direction that worsens the congestions would be reduced. As example, in case of Countertrading or Redispatching between 2 control area, Channel onshore TSOs might reduce available cross-border capacity on the borders between these 2 control areas to prevent intraday market trading further worsening the congestion and mitigating the relieving effect of the RA. The Available cross-border capacity in directions not impacting the RA negatively won't be modified. When timings allow, Agreed RAs will figure as inputs for the ID CC process (incl. IGMs).

4.4.2. Consideration of remedial actions in next IGM

Both the EU regulations (SO Guideline, CACM) and Methodologies (CGMM, CSAM) require that Agreed RAs shall be put into IGMs and also shall be distinguishable from the base ("clean") model. To be able to fulfil this requirement, Channel onshore TSOs aim to log all Agreed RAs in a platform separate from IGMs. CSAM article 28 requires RSCs to monitor inclusion of Agreed RAs into IGMs. To be able to do so, RSCs might for instance compare each TSOs IGMs against logged RAs and inform TSOs about identified inconsistencies.

Unlike ORA, the status of which won't be modified in next ID CROSAs, the logged information about ANORAs will be used to remove those ANORAs from CGM and hence get a "clean" CGM. In this way, Channel onshore TSOs and RSCs will be able to correctly identify congestions and possibly propose more efficient and effective set of RAs.

4.4.3. Fast activation process

Fast Activation Process is defined as a process to relieve operational security limits violation where detection of this violation occurs either between or after the standard CROSA processes. In such a situation, fast activation of a RA is required and cannot wait for the next ID CROSA. For example, in case a sudden operational security limits violation arises close to real-time or in real-time (due to incorrect forecast, unplanned outage, unavailability of a RA etc.), a TSO has the responsibility to

relieve the congestion as soon as possible. In case the RA meant to relieve the violation is not considered as XRA (has no cross-border impact), no coordination with RSCs or neighbouring TSOs is needed. However, in case it concerns a XRA (the RA has cross-border impact), the Fast Activation Process will be applied. When doing so, the activation of this XRA shall be coordinated with impacted TSOs (in Normal or Alert system state). In Emergency system state, when a violation occurs, coordination is recommended only if time allows it. If not, then affected TSOs would be only informed about the activation.

It might also happen that due to e.g. improved forecast, activation of certain RA is no longer necessary. In such cases, affected TSOs may reassess the need of the activation via Fast activation process. For example, cancelling a non-costly RA, such as topology change or PST tap change, might be very simple and easily done. However, cancelling RD or CT RA could be quite difficult when the generators have already started ramping etc. Therefore to decide whether to cancel activation of the RA, Affected TSOs have to carefully consider technical and operational feasibility and economic efficiency of doing so.

Depending on time restrictions, RSCs could be asked to participate in the Fast activation process and should be at least informed about its outcome once the constraint has been successfully relieved. Once RAs to relieve the violation has been identified, coordinated and agreed, the Fast activation process ends. Lastly, all RAs activated as a result of Fast activation process shall be taken into account in following IGMs. New congestions as a result of these RAs should be avoided.

5. IMPLEMENTATION

5.1. Monitoring

There are currently numerous existing European and national reporting and monitoring obligations regarding with RD and CT. Further regulations for monitoring and reporting, also based on the internal electricity market regulation, are currently being discussed.

With this background, it is crucial to analyse which reporting and monitoring requirements already exist and whether these are sufficient to fulfil the reporting and monitoring requirements for CCR Channel. Based on this, the additional needs have to discuss. This should be done in workshops in order to create mutual understanding of the processes as well as of the availability of the data, to discuss the meaningfulness and feasibility of the requirements and to clarify the respective expenditure involved. Thus, an efficient implementation of the necessary reporting and monitoring can take place.

5.2 Implementation

As described in the SO Regulation and CSAM, when developing solutions for the application of Coordinated Regional Security Analysis, TSOs and RSCs will consider the global efficiency and effectiveness. In this spirit, some of the functionalities and tools necessary for the ROSC need to be developed at regional and even pan-European level. Moreover, the CGMES format developed in accordance with the CGMM will be the basis for the target solution. Furthermore, the RSCs will aim at automatizing the optimisation step. Considering the different principles and the size of the Channel region, this automatization will represent a challenge that should not be underestimated. Overall, the

(in the future regional coordination centres) and references to SO Regulation. As a consequence, SO Regulation needs to be interpreted in the light of EMR and should not be considered as a stand-alone regulation.

6.1 Appointment of RSCs and delegation of tasks to RSCs

The Article 41 covers the formal appointment, by Channel onshore TSOs, of all RSCs that will perform the tasks listed in the article 77(3) of the SO Regulation, allocated by the model that shall be defined before formal approval of Channel ROSC Methodology.

TSOs of Channel CCR are shareholders of two separate RSCs, which are CORESO and TSCNET. Consequently, CORESO and TSCNET have been appointed as Channel RSCs to perform the tasks listed in the article 77(3) of SO Regulation and listed in Article 41.

6.2 Allocation of tasks between RSCs

Article 42 is describing how the tasks listed in article 41 are allocated between Coreso and TSCnet.

Regional operational security coordination

Regional operational security coordination will be carried out based on a Rotational Operating Model. In case of the **Rotational Operating Model**, two (or more) RSCs carry out a task on a rotational/alternating basis, while both (all) RSCs have a role in the process at each rotation period. The Leading RSC of a specific rotation period has the overall responsibility for the whole process, carries out the process and shares the output with the other RSC(s). For the parts of the process that require specific expertise on each TSO's grid and/or coordination/communication with the TSOs, the Backup RSC contributes with its expertise to support the Leading RSC, whenever needed. The Backup RSC has the overall responsibility to act as a redundant RSC for the Leading RSC whenever needed.

Example of the Rotational Model applied on CSA process:

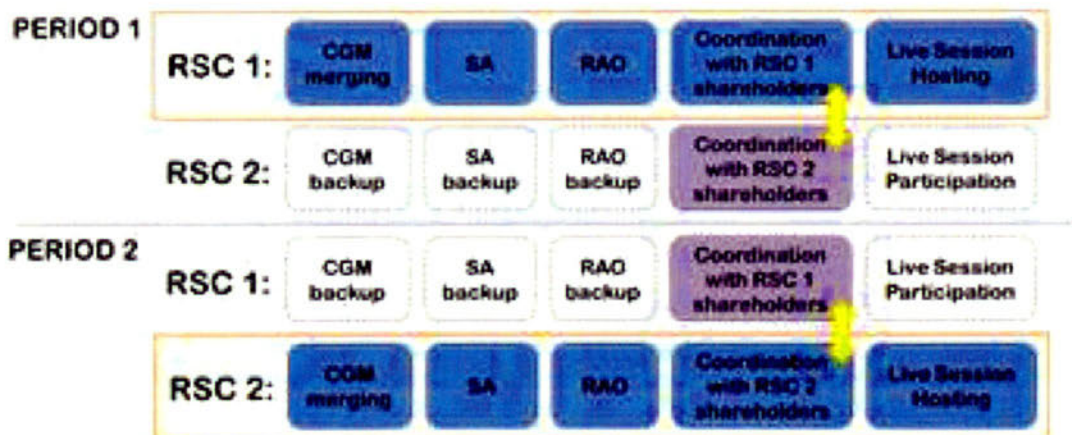

challenges and uncertainties behind the new processes and functionalities and the dependencies on parties, which are not part of the Channel governance, need to be considered within a realistic timeframe for the implementation of the target solution.

In this respect, Channel onshore TSOs and Channel RSCs have decided to describe in the Channel ROSC Methodology the different steps that will be necessary for the definition, the development and the testing of the target including an estimation of the maximum time for each step.

As the maximum timing of some of the steps will also be highly dependent of the development phase and is fixed when the contracts with the vendors are signed, it is also proposed to review and amend these timing in the Methodology once the tendering process for the different tools and hardware is finished.

Nevertheless, considering the importance to improve the efficiency of the coordination at the regional level, Channel onshore TSOs and Channel RSCs are aware and convinced that they cannot wait for the full implementation of the target solution. This is the reason why they also engage themselves to define and develop a stepwise approach considering interim solutions in a more ambitious but still realistic timing and to amend the Channel ROSC Methodology before 1 year after its approval accordingly. This stepwise approach and related interim solution shall be based on the following principles:

1. Improve the current level of coordination on Channel regional level, i.e. that the stepwise approach will respect the spirit and ambition of the provisions as defined in the Channel ROSC Methodology regarding the determination and activation of Agreed remedial actions and not develop a sub-regional solution;
2. Shall consider existing processes and tools without delaying the implementation of more advanced regional or pan-European solutions or processes when necessary, i.e. the interim solution might use the existing UCTE format and move to the CGMES format once this will be proven robust at pan-European level or might use a much simpler way to exchange and report data and results;
3. Shall be implemented faster and more ambitious, but within a realistic timing, i.e. Channel onshore TSOs and Channel RSCs expect this interim solution implemented in less than 24 months and
4. Shall require reasonable implementation effort, i.e. the required time and costs for the development and implementation of an interim solution have to be taken into account.

The Channel ROSC Methodology shall be implemented in a consistent manner with the Channel RD and CT Methodology and Channel Cost Sharing Methodology.

6. ALLOCATION OF TASKS BY RSCS

The elements that need to be described under the organisation of regional operational security coordination are further defined in article 77(1) of SO Regulation.

It should also be considered that on 4th July 2019 Electricity Market Regulation (EMR) entered into force that also contains in Art. 37 EMR tasks that shall be performed by regional security coordinators

The roles and the responsibilities of the Leading and Backup RSC are the following:

- Leading RSC:
 - is legally and operationally responsible and accountable for the successful start, execution and conclusion of the process (both in Day Ahead and Intraday timeframe);
 - ensures that all the steps of the process are fulfilled: delivery of data sets by TSOs, start and finish of each process step, reporting and communication of process results.
- Backup RSC:
 - facilitates coordination with the TSOs that are non-shareholders of the Leading RSC; each TSO maintains their contact with their RSC;
 - supports the Leading RSC in the design and proposal of sets of RA;
 - acts as redundancy to the Leading RSC in case of stressed situations on the network and inability of the Leading RSC in executing the process.

For the Rotational Model, Coreso and TSCnet will define the pre-defined period when establishing the high-level business solution referred to in article 40(5)(a) (for example weekly rotation). This predefined period can be modified by RSCs and TSOs if it is deemed more efficient.

Common grid model building

Within ENTSO-E, TSOs will set-up a consistent and harmonized approach at pan-European level to ensure that the solutions implemented to build Common Grid Models and operated by RSCs will be compliant with the respective requirements set up in the relevant legislation in force, including SOGL Regulation (notably Article 79(5)), the CGM methodology and the CSA methodology, while ensuring reliability of the CGM delivery process and the aligned use of the resulting unique CGM.

According to SOC decision (04/12/2019) all RSCs shall participate in the CGM building process on a rotational principle, with regular building and provision of a CGM by one main RSC and one backup RSC at all times. In addition, each RSC shall check the quality of the IGMs, according to Article 79(1) of the SO Regulation.

Regional outage coordination and regional adequacy assessment

OPC and STA tasks are already provided by Channel RSCs in accordance with methodologies developed in ENTSO-E for implementation of articles 80 and 81 of SO Regulation.

6.3 Assessment of the effectiveness and efficiency

The initial assessment of the effectiveness and efficiency of the proposed setup with the rotational model is included in Appendix 1 of the present Explanatory Note.

Article 43 defines the requirements how the effectiveness and efficiency will be monitored. ENTSO-E has to prepare each year by 30 September an annual report on regional coordination assessment based on the annual reports on regional coordination assessment provided by the regional security coordinators. The report has to assess any interoperability issues and propose changes aiming at improving effectiveness and efficiency in the system operation coordination according to SO Regulation Article 17, based on the reports prepared by RSCs.

RSCs will be faced with increased reporting obligations based on Art. 46 EMR. RSCs shall establish a process for the continuous monitoring of at least: (a) their operational performance; (b) the coordinated actions and recommendations issued, the extent to which the coordinated actions and

recommendations have been implemented by the transmission system operators and the outcome achieved; (c) the effectiveness and efficiency of each of the tasks for which they are responsible and, where applicable, the rotation of those tasks. Furthermore, RSCs shall submit an annual report on the outcome of the monitoring about this information on their performance to the ENTSO-E, ACER, the regulatory authorities in the system operation region and the Electricity Coordination Group. RSCs shall report any shortcomings that they identify in the monitoring process to the ENTSO-E, the regulatory authorities in the system operation region, ACER and the other competent authorities of Member States responsible for the prevention and management of crisis situations.

When preparing the reports, RSCs will have to detect the issues reducing the effectiveness and efficiency of the processes, allowing to suggest improvements in processes and allocation of tasks between the RSCs, covering also the requirements of Article 77.

6.4 Decision-making process and governance

Coordination decision-making processes and governance will be further defined in the High-level business solution defined Article 40(5)(a) which details the cooperation between RSCs and the contractual framework between Channel RSCs and TSOs.

APPENDIX 1: EFFICIENCY AND EFFECTIVENESS ASSESSMENT

Common provisions concerning the organisation of regional operational security coordination

Efficiency and Effectiveness Assessment

3 December 2019

1. EXECUTIVE SUMMARY

The RSCs have carried out an assessment of the efficiency and effectiveness of 3 likely operating models for allocation of tasks between RSCs: Rotational, Fully Rotational and Splitting Tasks. This assessment was carried against 4 key criteria: resourcing and high-level cost assessment, expertise, resilience and business change.

Rotational Operating Model: 2 (or more) RSCs carry out a task on a rotational/alternating basis, while both (all) RSCs have a role in the process at each rotation period. Leading RSC of a specific rotation period has the overall responsibility and liability for the whole process, Backup RSC contributes with its expertise to support the Leading RSC, for the parts of the process that require specific expertise on each TSO's grid and/or coordination/communication with the TSOs, and acts as redundancy to the Leading RSC in case of stressed situations on the network and/or inability of the Leading RSC in executing the process.

Fully Rotational Model: 2 (or more) RSCs carry out a task on a rotational/alternating basis. Each RSC carries out the task in full scope for a predetermined period, after which the RSC carrying out the task changes.

Splitting Tasks: for each of the tasks listed in SOGL article 77(3), one RSC carries out a task in full scope for all timeframes without support or backup from another RSC. Different tasks can be carried out by different RSCs, in which case the tasks are split between RSCs.

1.1 Advantages of the Rotational Operating Model

The significant advantages of the Rotational Model compared to other models are the following:

- **Resilience:** continuous backup by the Backup RSC ensures business continuity, minimises/avoids delays in the CSA process in case the Lead RSC process fails; Backup RSC role reduces the risks of miscommunication and lack of coordination in case of stressed situations
- **Resourcing and high-level cost assessment:** common IT solutions of RSCs provide significant savings in the development phase and reduce the operational costs of the IT solutions.
- **Expertise:** RSCs need less time compared to other models to build and maintain expertise on the TSOs power network and operational rules that is required to fulfil the obligation of designing and optimising sets of RAs, which will provide a significant saving on the training costs
- **Business change:** smooth transition towards the target model optimises the expertise needed, reduces the implementation risks and increases the transparency, saving cost both in the development stage and in operation.

2. INTRODUCTION. HIGH LEVEL EXPLANATION OF OPERATING MODELS

SOGL article 77(1)(c) requires that the proposals developed in each CCR include also ‘an assessment demonstrating that the proposed setup of regional security coordinators and allocation of tasks is efficient, effective and consistent with the regional coordinated capacity calculation established pursuant to Articles 20 and 21 of Regulation (EU) 2015/1222’.

There are several possible operating models; after initial analysis models based on parallel operation were excluded from the assessment because due to the overlapping implementation timelines compliance with CEP is recommended for the choice of operating model. The RSCs have carried out an assessment of the efficiency and effectiveness of 3 likely operating models for allocation of tasks between RSCs: Rotational, Fully Rotational and Splitting Tasks.

2.1 Rotational Operating Model

In case of the **Rotational Operating Model**, two (or more) RSCs carry out a task on a rotational/alternating basis, while both (all) RSCs have a role in the process at each rotation period. The Leading RSC of a specific rotation period has the overall responsibility for the whole process, carries out the process and shares the output with the other RSC(s). For the parts of the process that require specific expertise on each TSO’s grid and/or coordination/communication with the TSOs, the Backup RSC contributes with its expertise to support the Leading RSC, whenever needed. The Backup RSC has the overall responsibility to act as a redundant RSC for the Leading RSC whenever needed.

Example of the Rotational Model applied on CSA process:

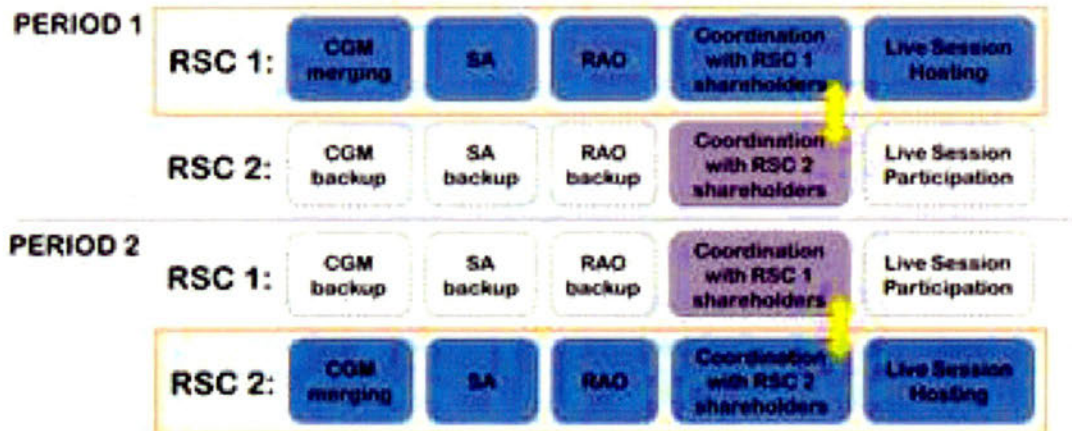

The roles and the responsibilities of the Leading and Backup RSC are the following:

- Leading RSC:
 - is legally and operationally responsible and accountable for the successful start, execution and conclusion of the process (both in Day Ahead and Intraday timeframe);
 - ensures that all the steps of the process are fulfilled: delivery of data sets by TSOs, start and finish of each process step, reporting and communication of process results.
- Backup RSC:
 - facilitates coordination with the TSOs that are non-shareholders of the Leading RSC; each TSO maintains their contact with their RSC;
 - supports the Leading RSC in the design and proposal of sets of RA;
 - acts as redundancy to the Leading RSC in case of stressed situations on the network and inability of the Leading RSC in executing the process.

The proposed setup is consistent with the capacity calculation process. For consistency, the RSCs may rotate the CSA task on a predetermined period, but this is subject for future definition in a contractual framework.

The advantage of the Rotational Model with Leading RSC is that it is also in line with CEP requirements, meaning that no major changes in the process will be required for the proposal of establishment of RCCs due in June 2020.

2.2 Fully Rotational Operating Model

In case of the **Fully Rotational Operating Model**, two (or more) RSCs carry out a task on a rotational/alternating basis. Each RSC carries out the task in full scope for a predetermined period, after which the RSC carrying out the task changes.

Example of the Fully Rotational Model applied on CSA process:

PERIOD 1



PERIOD 2

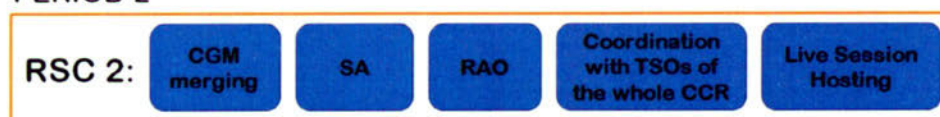

2.3 Splitting Tasks

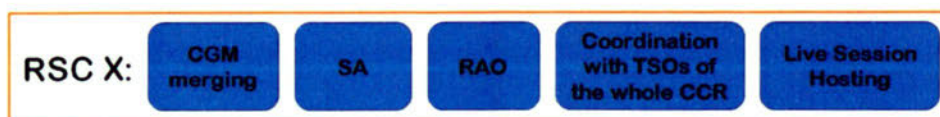

In case of Splitting Tasks, for each of the tasks listed in SOGL article 77(3), one RSC carries out a task in full scope for all timeframes without support or backup from another RSC. Different tasks can be carried out by different RSCs, in which case the tasks are split between RSCs.

3. COMPARISON OF THE OPERATING MODELS

High-level benchmarking table below provides a summary of the assessment that was carried out for each operating model against several criteria: redundancy/backup ensured, efficiency, effectiveness, consistency with CCC and other services, effective coordination and decision-making process, expertise, relations with non-stakeholders, compliance with CEP and costs.

| | Fully Parallel | Parallel with different perimeter | Fully Rotational | Rotational | Splitting Tasks |
|--|---|--|---|---|--|
| <i>Description</i> | <i>Both RSCs carry out the task for the whole CCR</i> | <i>Each RSC carries out the task for part of the CCR</i> | <i>One RSC carries out the task for all TSOs alternating with another RSC over time</i> | <i>One RSC carries out the task alternating and with support of another RSC for expertise</i> | <i>Only one RSC is appointed for the task in a CCR</i> |
| Redundancy/ backup ensured | ✓ | ? | ? | ✓ | ✗ |
| Efficiency | ✗ | ✓ | ? | ? | ✓ |
| Effectiveness | ✓ | ? | ? | ✓ | ✓ |
| Consistency with CCC | ✗ | ✗ | ✓ | ✓ | ✓ |
| Consistency with other services | ✗ | ✗ | ✓ | ? | ✗ |
| Effective coordination and decision making | ? | ? | ? | ✓ | ✓ |
| Expertise | ✗ | ✓ | ✗ | ✓ | ✗ |
| Relations with non-stakeholders | ? | ✓ | ✗ | ✓ | ✗ |
| Compliance with CEP | ✗ | ✗ | ✓ | ✓ | ✓ |
| Cost | ✗ | ✗ | ? | ? | ? |

✓ marks compliance with a criterion

✗ marks non-compliance with a criterion

? shows that further assessment is required to determine compliance with a criterion

It should be noted that the Parallel Operating Models are included in the comparison for reference; these models are considered rejected because significantly higher resources would be required, and these models are not compliant with CEP.

In the following chapters the 3 operating models – Rotational, Fully Rotational and Splitting tasks – are benchmarked against the key criteria.

3.1 Resourcing and high-level cost assessment

The key costs for RSCs are related to operational staff and IT tooling. **From the resourcing perspective, the Fully Rotational and the Rotational models present clear advantages.**

These operating models foresee only one RSC leading a task in a CCR at any given timeframe. In case of Rotational Model, only the Leading RSC will be responsible and accountable for the correct execution of the process and have dedicated resources to execute the task. The Backup RSC may share the workload of the Backup role between different regions.

The Rotational model would require 5 desks in 2 RSCs to cover the processes in 3 regions compared to 3 desks in case of the Fully Rotational Model or Splitting Tasks, but it ensures continuous backup that would not be there in case of the other 2 models. It is also important to note that since the implementation of the CSA service in full scope will be a major business change, Rotational Model is the only model that would allow a smooth transition optimising the expertise needed, saving cost both in the development stage and in operation.

The second significant component of costs is related to IT tools. In case of the Rotational Model the RSCs would share common IT solutions, providing significant savings in the development phase and reducing the operational costs of the IT solutions. It is also important to note that in addition, common IT solutions ensure transparency and facilitate the fulfilment of reporting obligations.

3.1.1 Operational arrangement with Rotational Model

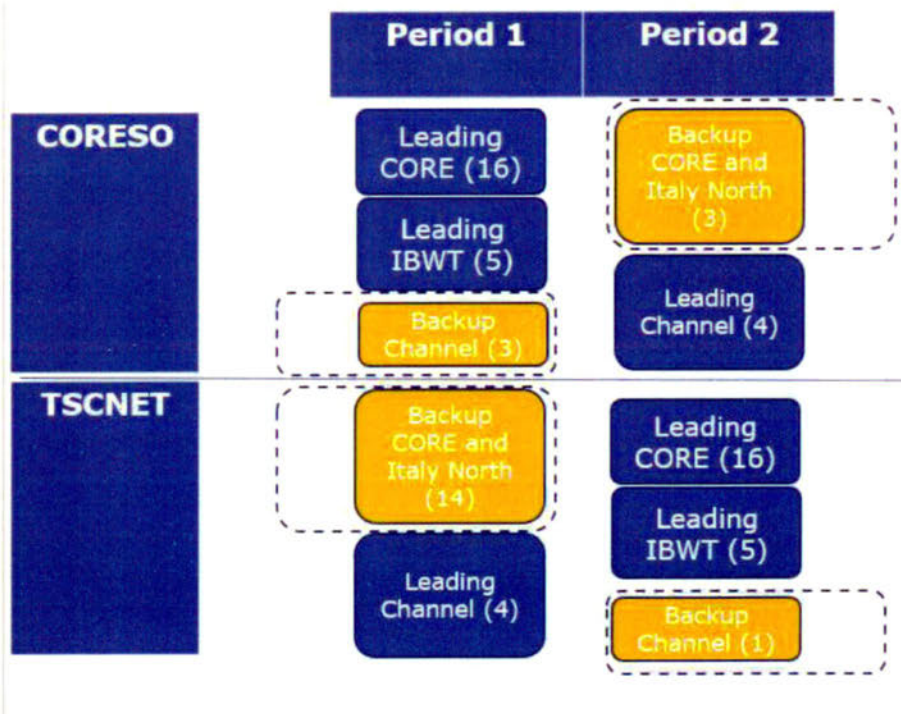

Shows potential combinations of backup desks with other regions (for example Channel backup and SWE). In (), the number of TSOs participating to the ROSC.

As shown above, the Leading RSC has one dedicated desk for each region that it is leading, for example CORE Lead has one desk dedicated to CORE CCR, Italy North Lead has one desk dedicated to Italy North CCR, while the Backup RSC has one desk for the backup function with the possibility to combine this backup desk also with other regions.

The advantages of this setup are resilience/security, optimal use of expertise and smooth change, as further elaborated in chapters 3.2-3.4. The expected higher need for the number of desks across 2 RSCs is well balanced by ensuring business continuity through continuous backup. Continuous backup will allow the Backup RSC to take over running the process in case the Lead RSC fails with minimal or no delays in the process.

The workload per desk in one RSC in the Rotational Model in day ahead and intraday timeframe is shown below:

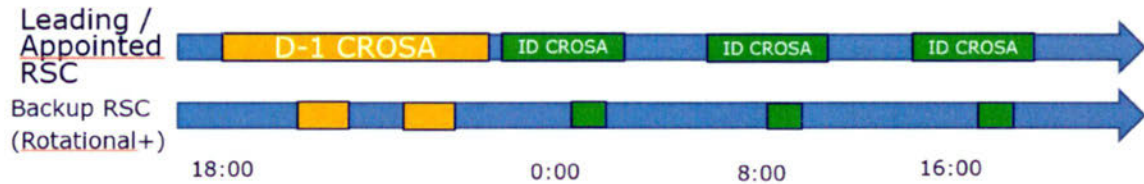

3.1.2 Operational arrangement with Fully Rotational Model

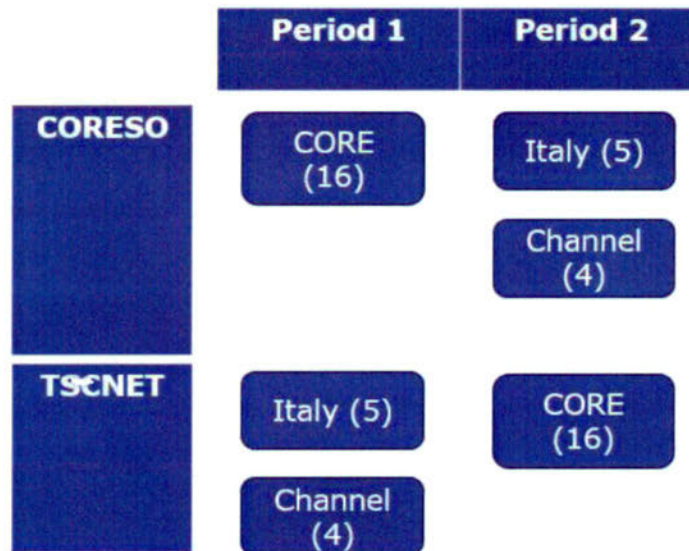

The advantage of the setup is that only 3 desks will be required across 2 RSCs, while the disadvantages are: no immediate backup, high workload for one RSC and RSCs need to build expertise on the whole CCR.

3.1.3 Operational arrangement if RSCs split tasks

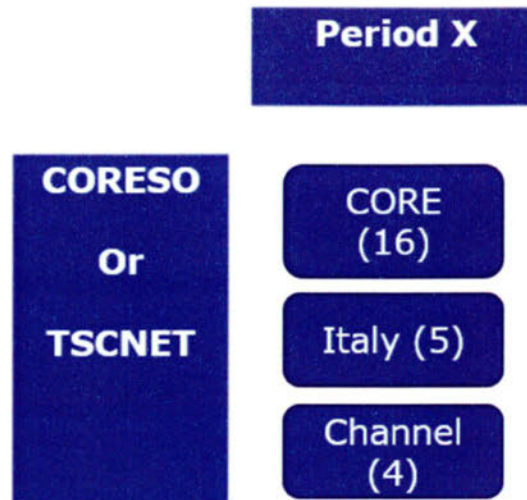

The disadvantages for the setup are massive change required in each RSC (reallocation of resources, building expertise), no backup ensured and the risk of lack of transparency and discriminatory behaviour (1 RSC runs the service for all TSOs « forever »).

3.2 Expertise

The CSAm requires RSCs to analyse, design and propose sets of Remedial Actions. This can be only done when an adequate level of expertise is kept at the RSC level. Furthermore, the Clean Energy Package requires that there is an official training and certification process for RCC personnel.

All of the 4 RSC tasks defined in SOGL require that the RSC has expertise on the TSOs power network and operational rules. This is necessary to fulfil the RSC role of designing and optimising sets of RA and also to develop and improve the RAO, among other roles, and will be required even with a high level of automation for the target process. The Fully Rotational or the Splitting Tasks models would require that one RSC has all the network and operational expertise for one region.

Taking the above into account, it is more expensive and riskier for a RSC to build up expertise and achieve a high level of maturity in the operational relations for the whole CCR, giving a clear advantage to the Rotational Model.

To achieve the level of expertise required to perform all the tasks, most notably to be able to analyse the results of security assessment, design and propose remedial actions, each operator will have to follow a training plan consisting of at least (i) a theoretical training on each TSO's power network and operating rules, and the procedures in each region, (ii) a practical training in the RSC control room working in parallel with an instructor, and, ideally (iii) a practical training in the control room of each TSO to further improve the understanding about each TSO's grid.

Based on a rough estimation and an assumption that both RSCs follow the same training plan, the table below gives an indication of the total time required to train one new operator to perform the tasks in case of each operating model.

| | ROTATIONAL | | FULLY ROTATIONAL | SPLITTING TASKS |
|--|---------------|---------------|------------------|-----------------|
| Number of TSOs for which expertise is required: | | | | |
| | CORESO | TSCNET | | |
| CORE | 3 | 14 | 16 | 16 ² |
| Italy North | 2 | 3 | 5 | 5 |
| Channel | 3 + ICs | 1 + ICs | 4 + ICs | 4 + ICs |
| Initial training: | CORESO | TSCNET | | |
| CORE | 4 months | 15 months | 18 months | 18 months |
| Italy North | 3 months | 2 months | 5 months | 5 months |
| Channel | 4 months | 1 month | 5 months | 5 months |
| Time required to maintain expertise: | CORESO | TSCNET | | |
| CORE | 5 days/year | 21 days/year | 26 days/year | 26 days/year |
| Italy North | 3 days/year | 5 days/year | 8 days/year | 8 days/year |
| Channel | 6 days/year | 3 day/year | 8 days/year | 8 days/year |

As seen in the table, the Rotational model will require less time both for initial training of the new operators, as well as for maintaining the expertise through continuous training.

Considering the notable staff turnover in the RSC control rooms, due to the conditions of secondment from TSOs and natural career evolution, the reduced time required for both initial and continuous training would provide a significant saving on the training costs.

3.3 Resilience

Ensuring security of supply requires that one RSC is available at all times, 24/7, to provide the coordination services to TSOs. In order to ensure this, a redundancy to the RSC that is executing the tasks is essential. The Fully Rotational and the Splitting Tasks operating models do not ensure redundancy. The Rotational Model ensures that there are RSC coordination rooms focused on the European network 24/7 so that there is full readiness to deal with critical grid situations, IT failures and other force majeure situations. With a Leading RSC and with a Backup RSC, there are also faster response times given the higher level of availability.

The communication and coordination between RSCs and TSOs are essential and, in case of stressed situations, the workload in the RSC's control rooms is very high, increasing the risk of miscommunication or even lack of coordination. There is a high number of stakeholders participating to in the CSA process that justify a structured coordination between RSCs and TSOs, and not only multiple TSOs to one RSC. **In case of the Rotational Model the Backup RSC can significantly**

² In the Core Region 50Hertz is counted on TSCnet and Coreso side, due to their participation in both RSCs.

reduce the risks mentioned above by supporting the Lead RSC with communication and coordination with its shareholder TSOs.

In the last decade there is a notable increase of operational risks due to increase of intermittent generation, increased capacity and variability of flows in the European network. The fact that no extensive or wide area incidents have been recorded in the interconnected European electricity network since the establishment of RSCs in 2009 is the best indicator of the effectiveness of the regional coordination.

ENTSO-E annual reports on Incident Classification Scale³ show that since the beginning of reporting in 2013 no blackouts (classified as scale 3 incidents according to the Incident Classification Scale) have occurred in any of the synchronous areas, and only a limited number of extensive incidents (classified as scale 2 incidents), when a TSO is in emergency state, have occurred, mainly in isolated systems of Iceland and Cyprus, where the SOGL requirements on regional coordination do not apply. Notable scale 2 incidents outside isolated systems were three N-violations (overloads on transmission lines classified as scale 2 incidents) in 2018 reported in Continental Europe, which were caused by unexpected high flows on the Switzerland and Italian border due to unexpected high production in Italy demonstrating further how crucial is the need for effective coordination in case of stressed situations.

CORESO Yearly Operational Reviews⁴ show that the number stressed situations has been increasing in most regions, for example in 2018 in South Central Europe (Italy North region) there were stressed situations in 61% of the business dates.

In case of stressed situations and/or when a TSO rejects a remedial action, the remedial action coordination step in the CSA process (between timings T1 and T2 in the 1st coordination run and between T3 and T4 in the 2nd coordination run) becomes more challenging, the number interactions between RSC and TSOs increase – on average there are 6 interactions (e.g. phone calls, e-mails) between a RSC and a TSO in such stressed situations. **In case of the Rotational Model these RSC-TSO interactions are divided between the RSCs, improving the quality of the services and reducing the risks of delay in the process.**

³ ENTSO-E reporting on Incident Classification Scale starting from 2017 (SOGL compliant) is available here - https://www.entsoe.eu/network_codes/sys-ops/annual-reports/#incident-classification-scale, earlier reports covering the years 2013-2016 are available here - <https://www.entsoe.eu/publications/system-operations-reports/#steering-group-operations>

⁴ Coreso Yearly Operational Reviews are available on Coreso website - <https://www.coreso.eu/operational-data/operational-review-2/>

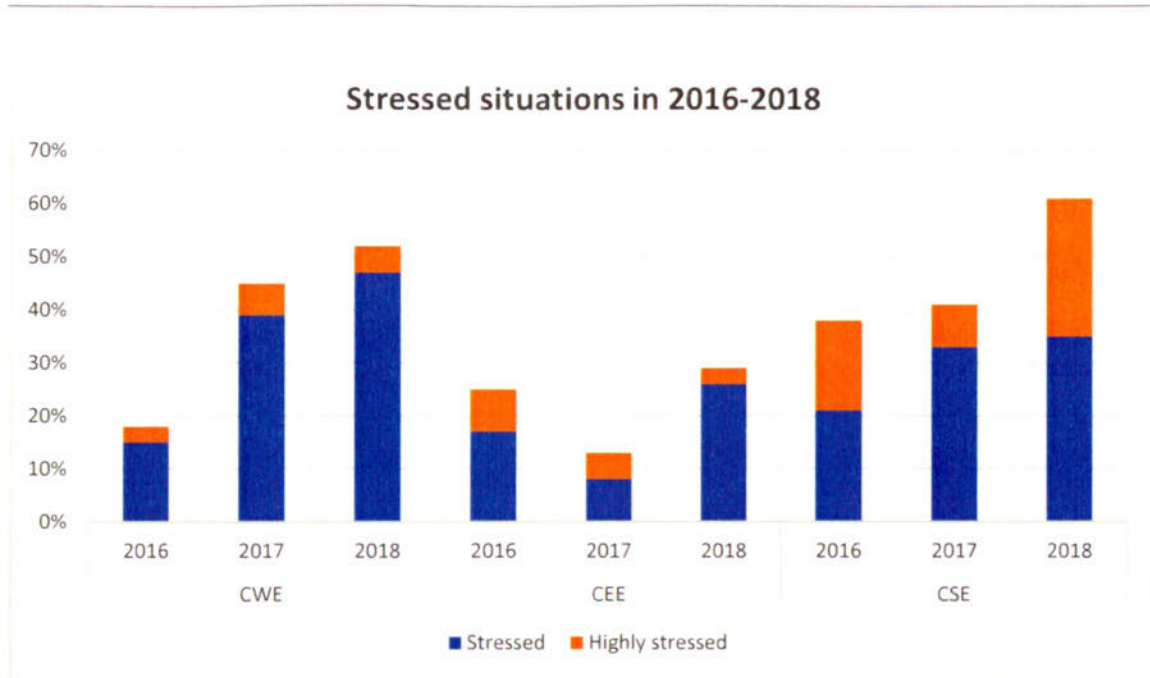

It is also important to note that often the interactions are multilateral including several TSOs in order to propose an acceptable set of remedial actions. The estimated total number of interactions between Coreso and TSOs during D-1 studies in case of data quality issues or conflicting remedial actions is **4745 interactions per year**.

| | CORE (CWE+CEE) | IBWT |
|---|-----------------------|------------------------|
| Number of days with coordinated actions | 190 (52%) | 222 (61%) |
| Estimated number of coordinated RAs | 950 RAs (2018) | 1110 RAs (2018) |
| Number of days with rejected RA | TBD | 213 (58%) |
| Estimated amount of cross-border RDCT avoided with the proposed coordinated RAs | TBD | 15 GW |

The graphs below illustrate the proportion between accepted and rejected RAs in the Italy North region in 2018 – sets of remedial actions proposed by TSOs have been rejected in more than 73 business dates, and RAs proposed by RSCs have been rejected on 140 business occasions.

SL>IT TARGET FLOW INCREASE REQUESTED BY CORESO 2018

■ Accepted ■ Denied

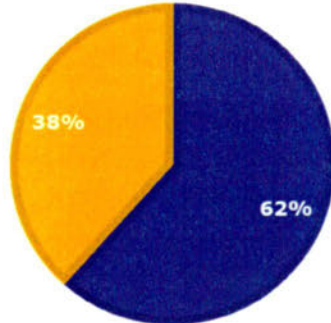

SL>IT TARGET FLOW DECREASE REQUESTED BY APG/ELES 2018

■ Accepted ■ Denied

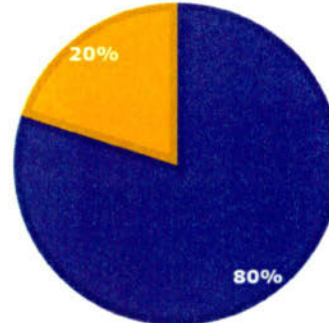

The coordination step can be supported by an IT solution (such as the Coordination Function) but it cannot be automated, especially in case of stressed situations and in case remedial actions proposed by RSC/RAO have been refused by a TSO. In addition, on the way to a fully automatized remedial action optimisation, while RAO tools are being developed and in a transition phase, RAO results may have to be challenged by an operator.

In case of the Rotational Model the Backup RSC can support the Lead RSC in the coordination step with the interactions with TSOs, finding alternative RA proposals in case of refusals by TSOs, challenging the results of RAO and also supporting in case of failures of the RAO tool. Based on the current experience, without the support of the backup RSC, it is unlikely that one RSC can complete the process in a timely manner. Especially in case of stressed situations there would be delays in the process that will affect all CCRs.

Also, the Rotational Model ensures that the relation between the Leading RSC and the non-shareholder TSOs will be efficient without the need for building trust and new operational relations. In case of the other models – Fully Rotational and Splitting Tasks – building relations between one RSC and non-shareholder TSOs will require time-consuming discussions around operational processes, contracts and operational interactions overall, which would be challenging or maybe even not feasible considering the current expectations of NRAs regarding the implementation timeframe.

Regarding decision-making, the concept of one Leading RSC adequately supported by a Backup RSC provides a robust decision-making process between the RSC and the remedial action owner (TSO). The complexity of the network, the intermittent generation and the number of parties involved result in risks for the security of the network that are more difficult to address when increasing the distance between the remedial action owner (TSO implementing the RA) and the decision-making stakeholders.

3.4 Business change

Implementation of the CSA process will require development of several tools (RAO, Coordination Function, CSA Input Consistency Function, etc), establishment of the operational processes,

introducing a link with other processes (STA, OPC, CCC), with other regions, etc. This is without a doubt a challenging undertaking, causing a huge change for both TSOs and RSCs. Considering this, it would be more reasonable to introduce the change in operational processes step-by-step, taking the maximum of the already existing processes and expertise, instead of making a dramatic change of all the processes/tools all at once. Implicitly, smoother change in the processes will minimise the impact on the security of supply.

The Rotational Model allows for a pragmatic and agile approach to the implementation, the already existing expertise and experience with the already established processes would be used most efficiently. The Rotational Model also prepares the RSCs and TSOs for the CEP implementation without creating new risks in the operational processes.

It is also important to note that implementation of other services already foresees huge change for TSOs and RSCs. Looking at the experience with other major projects, for example CGM Project, such step-by-step approach might be the only way to avoid critical delays in implementing the CSA process.

Main advantages of the Rotational Model:

- **Reduction of implementation risks:** minimising the magnitude of change over a time period will also minimise costs for RSCs and TSOs, dividing the total costs over a longer period of time, as well as ensuring that the costs borne are justified and contribute towards the end target (reducing also the risks related to managing the budget in case of scope changes), as well as minimising the risk for delays in the overall implementation project
- **Transparency:** through the Rotational Model, with both RSCs involved in the effective regional operational security coordination, the interoperability of tools and processes in one region and between different regions will be ensured. This will reassure that RSCs report on behalf of all TSOs and reinforce transparency and neutrality for the European consumer.

Main advantages of Splitting Tasks:

- **Effectiveness:** for the processes which are perceived not as critical to maintain a backup entity within the Region, the splitting of tasks allows the RSCs to focus their resources on less number of processes and at the same time increases their efficiency in terms of operational staff to be trained as well as the maintenance of IT tools and resources.

The Rotational model for time critical processes of high availability, including a Leading RSC and a Backup RSC, ensures an efficient and effective regional operational security coordination and allows for the correct, safe and timely execution of RSC tasks. While splitting the tasks for processes which are not as critical in terms of impact and timings, would be the most efficient way regarding staffing and IT resources.

It is also important to note that RSCs will annually have to detect the issues reducing the effectiveness and efficiency of the processes, allowing to suggest improvements in processes and allocation of tasks between the RSCs, covering also the requirements of Article 77. These assessments will allow to identify possible inefficiencies early on.